

IST-4-027756 WINNER II

D6.13.2

State-of-the-art evaluation (issue 1)

Contractual Date of Delivery to the CEC: 30/06/06

Actual Date of Delivery to the CEC: 30/06/06

Author(s): Martin Döttling, Jean-Philippe Javaudin, Kari Kalliojärvi, Göran Klang, Thomas Sälzer, Uwe Schwark, Antti Sorri, Carl Wijting

Participant(s): *BenQ, FTR&D, EAB, NOK, SAG*

Workpackage: *WP6 System concept*

Estimated person months: 5 PM

Security: PU

Nature: R

Version: v 1.0

Total number of pages: 38

Abstract:

The aim of this deliverable is to provide an overview on existing systems (standardised or proprietary) and systems that are still in standardisation. Key properties of 3GPP and its evolution, 3GPP2, IEEE 802.11n, IEEE 802.16e, IEEE 802.20 and FLASH-OFDM are highlighted and their system architectures are described. This deliverable shall serve as a guideline for the development of the WINNER system in that sense that it provides the set of legacy systems or system that will become legacy before WINNER will go into the market which WINNER will have to compete with. These systems thus provide a good indication on the performance targets WINNER has to achieve.

Keyword list:

3GPP, 3GPP2, IEEE 802.11n, IEEE 802.16e, IEEE 802.20, FLASH-OFDM®

Disclaimer:

Executive Summary

The aim of this deliverable is to provide an insight into key properties, and architectures of existing and emerging mobile radio and wireless systems, either standardised or proprietary. This insight shall serve as guideline for the development of WINNER target requirements and shall motivate the deployment of innovative features allowing WINNER to outperform these systems. Standards in the scope of this deliverable are 3GPP Release 99, 4, 5, 6 and E-UTRA, 3GPP2 1xEV-DO Revision A to C, IEEE 802.11 e/n/s, .16e, .20 and the proprietary technology FLASH-OFDM®.

Chapter 2 summarises the 3GPP standards family comprising release 99, 4, 5 and 6 by providing an introduction to the generic UMTS network architecture including a summary of network functions, corresponding elements and interfaces. In the sequel of chapter 2 specific features of release 99, 4, 5 and 6 are treated, where section 2.2 on Release 99 provides the basic technical information and the sections on the following releases highlight enhancements based on the respective predecessor release. Section 2.6 provides a deeper insight into the technical enhancements E-UTRA will bring. It highlights the E-UTRA deployment scenarios, target requirements considered to be of significant importance (peak data rates, spectrum efficiency and user plane latency) and their initial assessment compared to Release 6 performance. The gains reported for the downlink lie in the range of 2.5 - 3.2 times improvement of average spectral efficiency and 2 - 3 times improvement of the cell edge spectral efficiency per user over 3GPP Release 6. For the uplink improvements of approximately 2 - 3 times the reference 3GPP Release 6 performance for average and cell edge spectrum efficiencies are reported.

Chapter 3 first of all provides an overview on 3GPP2 and its organisation. In the sequel of chapter 3 3GPP2 enhancements 1xEV-DO Revisions A to C are highlighted by providing an overview of the major properties and targeted throughput figures. The information contained in this chapter represents the publicly available material, which goes not into the very technical details. However, it is expected that official standards documents will be available soon, which will then be taken into account for the follow-up version of this deliverable.

Chapter 4 provides an overview on the IEEE 802 standards family members which WINNER will likely have to compete with when being deployed. These are IEEE 802.11e (MAC QoS enhancements) .11n (enhancements for higher throughput) .11s (mesh networking), 802.16 (Broadband Wireless Access), .16e (mobility enhancements for 802.16), 802.20 (Mobile Broadband Wireless Access) and 802.21 (Media Independent Handoff). 802.11e/n/s standards are seen to be relevant for benchmarking the WINNER Local Area solution, whereas 802.16e and 802.20 (Mobile Broadband Wireless Access) are seen as relevant systems for benchmarking the WINNER Metropolitan and Wide Area deployments. IEEE 802.11n aims at providing 100 Mbps above the MAC layer Service Access Point, which has to be significantly exceeded by WINNER. Mobile Broadband Wireless Access Standards (.16, .20) are designed for user peak data rates in order of several Mbps and thus will particularly challenge the WINNER solution for Metropolitan Area Deployments. Peak downlink spectrum efficiency targeted by IEEE 802.20 is 3.6 b/s/Hz/sector, whereas a sustained spectrum efficiency of 1.8 b/s/Hz/sector is envisaged for the downlink. These values lie close to the spectrum efficiency figures envisaged by WINNER.

Chapter 5 provides an overview on the proprietary mobile radio technique FLASH-OFDM owned by Qualcomm. FLASH-OFDM is a technology intended for Wide and Metropolitan Area deployment supporting mobility of up to 250 km/h and downlink peak and sustainable data rates of 3.2 and 1.25 Mbps respectively with a 1.25 MHz wide carrier. Configurations with a wider carrier bandwidth are possible which lead to higher data rates. Average spectrum efficiencies, however, lie in the range of 1 bit/s/Hz/sector in the downlink and approximately 0.4 bit/s/Hz/sector in the uplink. FLASH-OFDM does not target very high data rates and spectrum efficiencies and thus is seen to be neither a direct competitor for WINNER Metropolitan nor Wide Area deployments. However, FLASH-OFDM addresses the topic of very low ARQ loop time of 5 ms to tackle latency requirements of IP-based protocols such as TCP/IP. This topic will be also very important for the WINNER system design and must be carefully addressed.

Chapter 6 provides as conclusion a comparison of E-UTRA, 3GPP2 1xEV-DO Revision B, IEEE802.11n, .16e, .20 and FLASH-OFDM® with respect to their achievable spectrum efficiencies. Furthermore, peak and average spectrum efficiencies as forecasted by the ITU are reported and compared with the WINNER targets.

Authors

Partner	Name	Phone / Fax / e-mail
FTR&D France Telecom R&D	Jean-Philippe Javaudin	Phone: +33 2 99 12 45 95 Fax: +33 2 99 12 40 98 e-mail: jeanphilippe.javaudin@orange-ft.com
FTR&D France Telecom R&D	Thomas Sälzer	Phone: +33 2 45 29 64 80 Fax: +33 2 45 29 41 94 e-mail: thomas.salzer@orange-ft.com
BenQ BenQ Mobile GmbH & Co. OHG	Uwe Schwark	Phone: +49-2842-95-2257 Fax: +49 2842 95 3387 e-mail: uwe.schwark@benq.com
EAB Ericsson AB	Göran Klang	Phone: +46-8-404 4794 Fax: +46-8-585 31480 e-mail: goran.n.klang@ericsson.com
SAG Siemens AG	Martin Döttling	Phone: +49-89-636-73331 Fax: +49-89-636-1373331 e-mail: martin.doettling@siemens.com
NOK Nokia Oyj	Kari Kalliojärvi	Phone: +358-50-4836232 Fax: +358-718035935 e-mail: kari.kalliojarvi@nokia.com
NOK Nokia Oyj	Antti Sorri	Phone: +358-50-4821294 Fax: +358-718036857 e-mail: antti.sorri@nokia.com
NOK Nokia Oyj	Carl Wijting	Phone: +358-50-4860564 Fax: +358-718036857 e-mail: carl.wijting@nokia.com

Table of Contents

1. Introduction	9
2. 3GPP Standards	9
2.1 UMTS Generic Architecture	9
2.2 Release 99.....	11
2.3 Release 4.....	13
2.4 Release 5.....	14
2.5 Release 6.....	15
2.6 3GPP Long Term Evolution (LTE)	16
2.6.1 E-UTRA Deployment Scenarios.....	16
2.6.2 E-UTRA key features.....	17
2.6.2.1 Downlink	17
2.6.2.2 Uplink	17
2.6.3 Expected Performance of E-UTRA.....	18
2.6.3.1 Peak Data Rates	18
2.6.3.2 Spectrum Efficiency and User Throughput.....	19
2.6.3.3 User Plane Latency	19
3. 3GPP 2 Standards	20
3.1 3GPP2 1xEV-DO	20
3.1.1 3GPP2 1xEV-DO Revision A	20
3.1.2 3GPP2 1xEV-DO Revision B (DO Multicarrier).....	21
3.1.3 3GPP2 1xEV-DO Revision C	21
4. IEEE Standards	21
4.1 IEEE 802.11 Wireless LAN	21
4.1.1 Medium Access Control Quality of Service Enhancements (IEEE 802.11e).....	22
4.1.2 Enhancements for Higher Throughput (IEEE 802.11n).....	23
4.1.3 Mesh Networking (IEEE 802.11s).....	24
4.2 IEEE 802.16 Broadband Wireless Access.....	24
4.2.1 Physical Layer Properties of IEEE 802.16e	25
4.2.2 Performance of IEEE 802.16e.....	25
4.2.3 Deployment Options and WiMAX Profiles	25
4.2.4 WiMAX Network Architecture.....	26
4.2.5 Timescale	26
4.3 IEEE 802.20 Mobile Broadband Wireless Access	26
4.4 IEEE 802.21 Media Independent Handoff	28
4.5 Relevance of IEEE Standards for Benchmarking the WINNER System	28
5. FLASH-OFDM®	29
5.1 Introduction/Background.....	29
5.2 Technology.....	29
5.2.1 Overview.....	29
5.2.2 Physical Layer.....	30
5.2.2.1 Transmission Scheme	30
5.2.2.2 Coding and Modulation	32
5.2.3 MAC and Link Layers	32
5.2.4 Network Layer	33
5.2.5 FLASH-OFDM System Parameters and Characteristics	33
5.2.6 Summary	34
5.3 Standardisation and Commercial Availability	35
5.3.1 Standardisation.....	35
5.3.1.1 Network Standards.....	35
5.3.1.2 Air Interface Standards	35
5.3.2 Commercial Availability	35

6. Conclusion 35

References 37

List of Acronyms and Abbreviations

1xEV-DO	1x Evolution-Data Only
3G	3 rd Generation mobile communication systems
3GPP	3 rd Generation Partnership Project
3GPP2	3 rd Generation Partnership Project 2
ACK	Acknowledge
AMC	Adaptive Modulation and Coding
AMR	Adaptive Multi-Rate
AP	Access Point
ARQ	Automatic Repeat Request
AUC	Authentication Center
BCH	Broadcast Channel
BMSC	Broadcast Multicast Serving Center
BS	Base Station
BSS	Basic Service Set
CCK	Complementary Code Keying
CDG	CDMA Development Group
CDMA	Code Division Multiple Access
CLTD	Closed-Loop Transmit Diversity
CN	Core Network
CPCH	Common Packet Channel
CQI	Channel Quality Indicator
CRNC	Controlling RNC
CS	Circuit Switched
CSMA/CA	Carrier Sense Multiple Access with Collision Avoidance
CTC	Convolutional Turbo Code
CTS	Clear To Send
CW	Contention Window
DC	Direct Current
DCF	Distributed Coordination Function
DCH	Dedicated Transport Channel
DFT	Discrete Fourier Transform
DIFS	Distributed Inter-Frame Space
DRNC	Drift RNC
DS	Distribution System
DS-CDMA	Direct Sequence CDMA
DSCH	Downlink Shared Channel
DSSS	Direct Sequence Spread Spectrum
DVB	Digital Video Broadcast
DVB-H	DVB-Handheld
ECC	Electronic Communications Committee
E-DCH	Enhanced DCH
EIR	Equipment Identity Register
eNB	evolved Node B
ESS	Extended Service Set
ETSI	European Telecommunications Standards Institute
E-UTRAN	Evolved-UTRAN
FACH	Forward Access Channel
FDD	Frequency Division Duplex
FDMA	Frequency Division Multiple Access
FEC	Forward Error Correction
GGSN	Gateway GPRS Support Node
GMSC	Gateway MSC
GPRS	General Packet Radio Service
GSM	Global System for Mobile Communications
HARQ	Hybrid Automatic Repeat Request
HCCA	HCF Controlled Channel Access
HCF	Hybrid Coordination Function
HLR	Home Location Register
HO	Handover

HSDPA	High-Speed Downlink Packet Access
HS-DSCH	High-Speed Downlink Shared Channel
HSUPA	High-Speed Uplink Packet Access
HT	High Throughput
IEEE	Institute of Electrical and Electronics Engineers
IFDMA	Interleaved FDMA
IMS	IP Multimedia Subsystem
IMT	International Mobile Telecommunications
IP	Internet Protocol
IR	Incremental Redundancy
ISIM	IMS Services Identity Module
ITU	International Telecommunications Union
LDPC	Low-Density Parity-Check
LTE	Long Term Evolution
MAC	Medium Access Control
MBMS	Multimedia Broadcast Multicast Service
Mbps	Megabit per second
MGW	Media Gateway
MIB	Management Information Base
MIMO	Multiple-Input Multiple-Output
MMR	Mobile Multi-hop Relay
MMS	Multimedia Messaging Service
MSC	Mobile Services Switching Center
MU-MIMO	Multi-User MIMO
NBAP	Node B Application Protocol
OFDM	Orthogonal Frequency Division Multiplexing
OFDMA	Orthogonal Frequency Division Multiple Access
PAPR	Peak-to-Average Power Ratio
PAR	Project Authorization Request
PC	Power Control
PCH	Paging Channel
PoC	Push-to-Talk over Cellular
PS	Packet Switched
PUSC	Partially Used Sub-Channel
PUSC	Partially Used Sub-Channel
QAM	Quadrature Amplitude Modulation
QoS	Quality of Service
QPSK	Quadrature Phase Shift Keying
RACH	Random Access Channel
RAN	Radio Access Network
RANAP	RAN Application Part
RAT	Radio Access Technology
RIFS	Reduced Inter-Frame Space
RLC	Radio Link Control
RNC	Radio Network Controller
RNS	Radio Network Subsystem
RNSAP	RNS Application Protocol
RRC	Radio Resource Control
RTS	Request To Send
SC-FDMA	Single Carrier - FDMA
SF	Spreading Factor
SFN	Single Frequency Network
SGSN	Serving GPRS Support Node
SI	Study Item (in 3GPP)
SIP	Session Initiation Protocol
SRNC	Serving RNC
STA	Station
STTD	Space-Time Transmit Diversity
SU-MIMO	Single-User MIMO
TDD	Time Division Duplex
TG	Task Group
TR	3GPP Technical Report

TS	3GPP Technical Specification
TSG	3GPP Technical Specification Group
TSPEC	Traffic Specification
TTI	Transmission Time Interval
TxOP	Transmission Opportunity
UE	User Equipment
UMTS	Universal Mobile Telecommunication System
USCH	Uplink Shared Channel
USIM	Universal Subscriber Identity Module
UTRA	UMTS Terrestrial Radio Access
UTRAN	UMTS Terrestrial Radio Access Network
VLR	Visitor Location Register
VoIP	Voice over IP
W-CDMA	Wideband CDMA
WG	Working Group
WI	Work Item (in 3GPP)
WiFi	Wireless Fidelity
WLAN	Wireless Local Area Network
WRC	World Radiocommunication Conference
WWRF	Wireless World Research Forum

1. Introduction

The aim of this deliverable is to provide an overall view of existing systems (standardised or proprietary) and systems that are still under standardisation phase. It is the first one of two versions that will be released over two year's period of the project (see Table 1-1 below).

D6.13.2	State-of-the-art evaluation issue 1	Mth6
D6.13.9	State-of-the-art evaluation issue 2	Mth18

Table 1-1: Time plan for deliverables related to the WINNER II standardisation plan

This document will be a reference basis for a further comparison of WINNER II performances with existing systems. As this initial version the State-of-the-art evaluation is due prior to the release of the WINNER II intermediate system concept, no assessment and no comparison to WINNER II system performance is included in this first document. However, wherever possible, this document states identified critical issues in system concept and design of legacy systems, and derives overall recommendations and directions for further work in WINNER II based on these experiences.

The various systems referred to in this document are: 3GPP, IEEE 802.11/802.16/802.20, 3GPP2 and FLASH-OFDM. For the description of these systems the focus is put on the deployment scenarios and on the performance. A picture of their architecture is also recalled in this document. For a clarity and concision purpose, the goal of this document is not to provide a complete description of these systems, consequently adequate references to standards documents are provided.

2. 3GPP Standards

2.1 UMTS Generic Architecture

The universal mobile telephony system (UMTS), also known as wideband code division multiple access (W-CDMA), is a third generation mobile communication standard promoted by ETSI to meet the requirements of IMT-2000.

A UMTS network consist of three interacting parts, a core network (CN), a UMTS terrestrial radio access network (UTRAN), and one or more user equipments (UE) [23.101], cf. Figure 2-1. The interaction between the CN and the UTRAN takes place over the Iu interface, whereas the interaction between the UTRAN and the UE takes place over the air interface commonly referred to as the Uu interface.

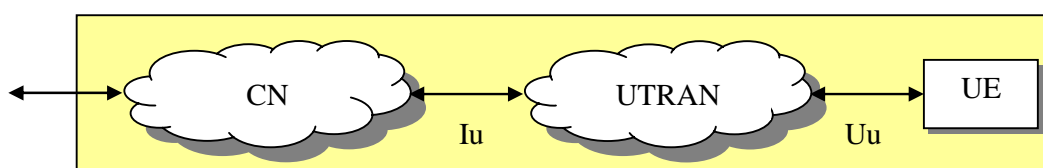

Figure 2-1: Overall picture of the UMTS architecture

The main function of the core network is to provide switching, routing and transit for user traffic. The core network also contains databases and network management functions. The basic CN architecture for UMTS is based on the GSM/GPRS CN architecture, cf. Figure 2-2. It contains several network elements of circuit switched and packet switched types. Some of the circuit switched elements are for example the Mobile Services Switching Center (MSC), the Visitor Location Register (VLR) and the Gateway MSC (GMSC). Examples of packet switched elements are the Serving GPRS Support Node (SGSN) and the Gateway GPRS Support Node (GGSN). Additionally, some network elements, like the Equipment Identity Register (EIR), Home Location Register (HLR), Visitor Location Register (VLR) and Authentication Center (AUC) are shared by both domains.

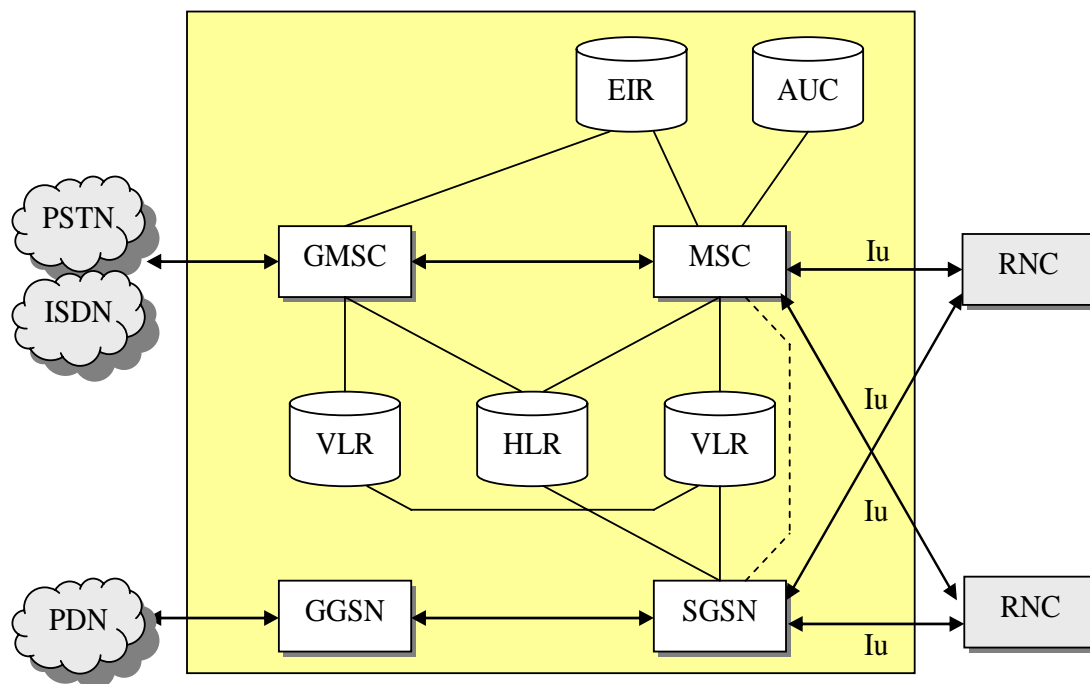

Figure 2-2: CN architecture

The UTRAN provides the air interface access method for the UE. The architecture of the UTRAN [25.401] is shown in Figure 2-3. Base Stations are referred to as Node Bs and communicate with the UEs via the Uu interface. The control equipment for the Node Bs is called Radio Network Controller (RNC). One RNC controls multiple Node Bs. An RNC and its associated Node Bs form a so called Radio Network Subsystem (RNS). A UTRAN is composed of several RNSs. The Iu interface connects UTRAN to a core voice network (Iu-CS) or to a core data network (Iu-PS) using RANAP as main signalling protocol. The Iur interface connects RNCs and its primary purpose is to support mobility. The main signalling protocol used is RNSAP. The Node Bs are controlled by an RNC using NBAP protocol and the Iub interface.

The Controlling RNC (CRNC) of a Node B is the RNC that terminates the Iub interface of this Node B. From the view of a particular UE-UTRAN connection, a RNC can have two logical roles: when a mobile subscriber has connections to cells served by different RNCs, the so-called Serving RNC (SRNC) provides the transport of user data to the core network and terminates the RANAP protocol as well as the RRC signalling. It performs L2 processing and basic RRM. The Drift RNC (DRNC) is any other RNC that controls cells used by the mobile (e.g. by use of soft handover). The DRNC routes data transparently over the Uub and Iur interfaces, except in case of common or shared transport channels (cf. Figure 2-3).

Two horizontal layers are distinguished: the Radio Network Layer, which encapsulates all UTRAN-specific issues, and the Transport Network Layer, that contains standard transport technology without UTRAN-specific changes. UMTS-specific control signalling and the associated application protocols (RANAP, RNSAP, NBAP) are part of the Control Plane, whereas the User Plane transports all information data streams sent and received by the user [HT04].

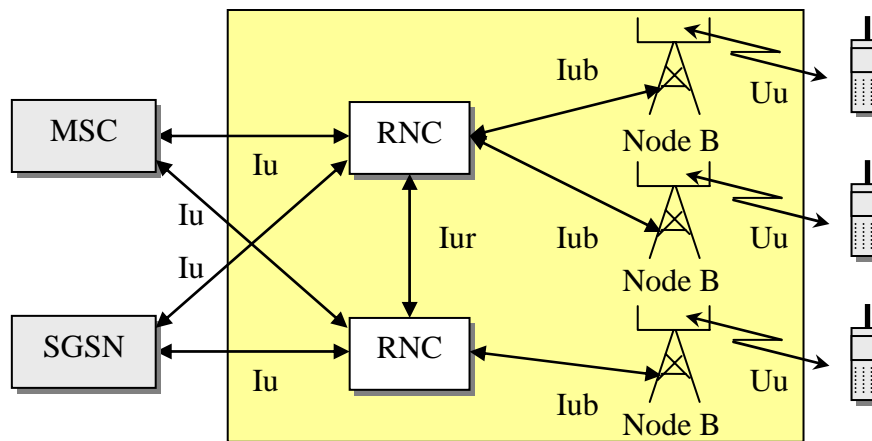

Figure 2-3: UTRAN architecture

The RNCs are the nodes of the UTRAN enabling autonomous radio resource management (RRM). The functions of RNC are:

- Radio Resource Control
- Admission Control
- Channel Allocation
- Power Control Settings
- Handover Control
- Macro Diversity
- Ciphering
- Segmentation / Reassembly
- Broadcast Signalling
- Open Loop Power Control

The Node B is the logical node of the UTRAN RNS handling air interface processing. The node terminates the Iub interface towards the RNC. The functions of Node B are:

- Air interface Transmission / Reception
- Modulation / Demodulation
- CDMA Physical Channel coding
- Interleaving
- Rate Adaptation
- Micro Diversity
- Error Handling
- Closed loop power control

2.2 Release 99

The initial UMTS deployments are often based on the specification Release 99 of the UMTS standard. Release 99 was frozen in December 1999. It specifies the UTRAN, which is typically added to circuit-switched voice infrastructure and GPRS "Internet access". Further features, like a basic open service architecture, the narrowband Adaptive Multi-Rate (AMR) codec, Multimedia Messaging Service (MMS) and updates for location services were also part of Release 99.

UTRAN offers a new air interface based on W-CDMA, which has two basic modes of operation: Frequency Division Duplex (FDD) and Time Division Duplex (TDD). Main air interface parameters are compiled in Table 2-1.

Table 2-1: Main air interface parameters of UMTS Release 99

Multiple Access	DS-CDMA
Duplexing	FDD / TDD
Carrier Frequency	in Europe: FDD UL: 1920-1980MHz FDD DL: 2110-2170MHz

	TDD: 1900-1920MHz and 2020-2025MHz
Bandwidth / Carrier Spacing	5 MHz
Chip Rate	3.84 Mcps
Frame Structure	Frame length: 10 ms containing 15 slots
Multirate Concept	Variable spreading factor, multi-code transmission,
Synchronisation	asynchronous base stations
Detection	coherent based on common and dedicated pilot signals
Modulation	QPSK in DL and UL, BPSK for RACH, CPCH
FEC	Convolutional Codes R=1/2 and R=1/3, constraint length 8, Turbo Code R=1/3, 8-state parallel concatenated convolutional code, variable code rates by repetition and puncturing

The new network elements introduced as part of UMTS Release 99 are the RNC and the Node B, which have been described in the previous section.

The transport channels defined in Release 99 are:

- Dedicated Transport Channels (DCH),
- Paging Channel (PCH),
- Broadcast Channel (BCH),
- Forward Access Channel (FACH),
- Random Access Channel (RACH),
- the Uplink Common Packet Channel (CPCH),
- Downlink Shared Channel (DSCH) for both FDD and TDD modes and the
- Uplink Shared Channel (USCH) in TDD mode only.

Their main characteristics are summarized in Table 2-2, where SF denotes Spreading Factor, PC Power Control, HO Handover, STTD Space-Time Transmit Diversity (Alamouti space time block coding), and CLTD Closed-Loop Transmit Diversity.

Regarding spatial processing, FDD mode operation prevents use of reciprocity to obtain short-term channel state information at the transmitter. Therefore, in the closed-loop transmit diversity modes, feedback information is used to adjust the transmitted phase and/or amplitude of the antennas. However, due to the limited payload available for this feedback (1 bit per 0.667 ms)¹ only coarse information can be obtained and feedback reliability is limited. These constraints limit the overall performance achievable by MIMO processing. Therefore, careful design of feedback channels and alternative ways to obtain short-term channel state information at the transmitter are considered important research topics in WINNER.

Table 2-2: Main characteristics of UMTS Release 99 transport channels

	dedicated channels	common channels					shared channels	
	DCH	PCH	BCH	FACH	RACH	CPCH	DSCH	USCH
UL/DL	↑↓	↓	↓	↓	↑	↑	↓	↑ (only TDD)
SF	4-256(512)	4-256	256	4-256	32-256	4-256	4-256	4-256
fast PC	✓	–	–	–	–	✓	✓	✓
slow PC	✓	–	–	✓	✓	✓	✓	✓
soft HO	✓	–	–	–	–	–	–	–
Tx diversity	STTD / CLTD	STTD	STTD	STTD	–	–	STTD / CLTD	–
beam-forming	✓	–	–	✓	–	–	✓	–

¹ Feedback delay between measurement and adjustment of transmission is in the order of 1 – 2 slots.

	dedicated channels	common channels					shared channels	
	DCH	PCH	BCH	FACH	RACH	CPCH	DSCH	USCH
packet data amount	medium / large	no packet data	no packet data	small	small	small / medium	medium / large	medium / large
bursty packet data	–	no packet data	no packet data	✓	✓	✓	✓	✓

Inter-system and inter-carrier handover requires measurements at other frequencies and acquisition of the control channel of other systems or carriers. UMTS uses the compressed mode, to generate a transmission gap of a few ms duration by compressing the data stream. This transmission gap can be used for measurements.

In the future deployment of WINNER the importance and frequency of inter-RAT and inter-mode handover is considered to be increased compared to the current situation. Therefore, efficient support for handover and interworking by the required procedures and measurements deserves thorough investigation.

Release 99 offers a maximum user data rate of 2 Mbps (although it is initially often limited to 384 kbps) in 5 MHz bandwidth. Spectral efficiency is in the order of 0.5 bps/Hz/cell/carrier [Jav05].

2.3 Release 4

The content of Release 4 was frozen in March 2001. Release 4 specifications provide efficient IP support enabling provision of services through an all-IP core network. Moving to a packet-switched core voice network allows flexible re-use and statistical multiplexing of resources.

Other functional areas are also covered by Release 4, such as broadcast services, multimedia messaging and network-assisted location services. Furthermore, the low chip rate TDD mode was introduced and terminal power saving features were integrated.

In Release 4, the MSC functionality is split into two logical functions, which will typically be provided by physically separate network elements, namely:

- Media Gateway (MGW)
- MSC Server.

The bearer switching (and conversion) functions of the MSC are now provided by the MGW, which also contains transcoders and echo cancelling.

The control functions of the MSC are now provided by the MSC Servers. The Gateway MSC Server is an MSC Server that controls the connections to other networks, e.g. the PSTN. The MSC Server provides all the call control capabilities required by the MGW. The MSC Server is also responsible for Mobility Management. Typically, the MSC Server also contains VLR functionality.

A single MSC Server can control multiple MGWs. This provides major scalability benefits. That is, when extra capacity is needed, it may be possible to add only a new MGW and utilize an existing MSC Server.

The Mc interface is used by the MSC Server to control the MGWs. The Nc interface is used to share signalling information between multiple MSC Servers involved in a session (e.g. a voice call). This in turn allows the relevant MGWs to be effectively controlled for the duration of the call. The Nb interface is used to transport data (e.g. voice packets) between MGWs. For example, one MGW may be connected to the UTRAN and another MGW is connected to the PSTN, with the voice packets being transferred between them using the Nb interface [IEC05].

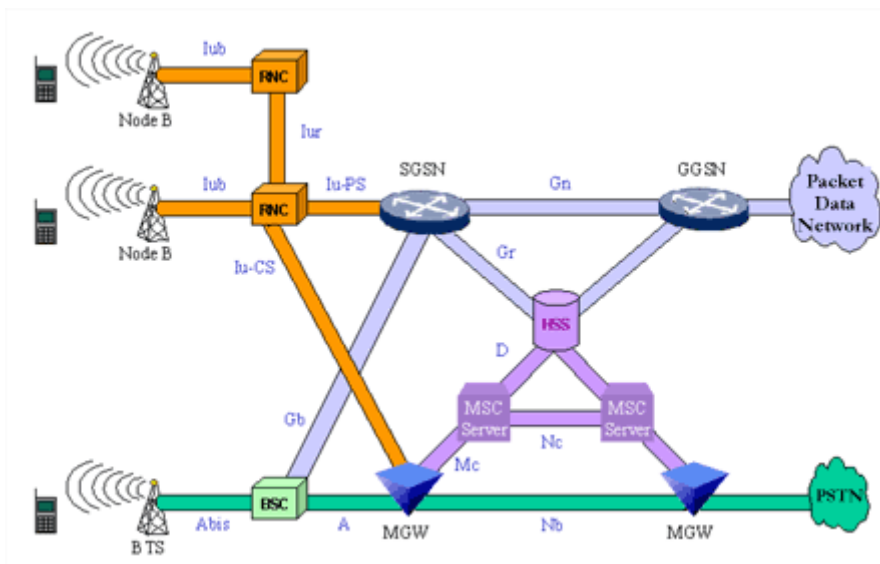

Figure 2-4: Release 4 specific architecture [IEC05].

Release 4 doesn't provide significant improvements in user data rates and spectral efficiency compared to Release 99.

2.4 Release 5

Release 5 specifications were frozen in June 2002 [25.858] [25.950]. Main features include the development of the wideband AMR codec, end-to-end QoS in PS domain, IP-based Multimedia Services, IP Multimedia Subsystem (IMS) using the Session Initiation Protocol (SIP) to support real-time multimedia services, and the introduction of High Speed Downlink Packet Access (HSDPA).

The IP Multimedia Subsystem (IMS) provides a flexible architecture for the rapid adoption of IP-based multimedia, like integrated media, voice, text, picture, video services [MCC03]. Within the IMS, media control, session control, and application control are separated in distinct entities. Some of the first applications using the standard are Push-to-Talk over Cellular (PoC), Presence and Instant Messaging and many other interactive services. These applications can use a variety of basic network services offered by IMS like:

- session control services including subscription, registration, routing and roaming,
- combination of several different media bearer per session,
- central service based charging,
- secure authentication and confidentiality based on the ISIM/USIM,
- quality of service support.

SIP is a text-based protocol used by the IMS (e.g. in the communication of the IMS session control entity and the RNC) for internet conferencing, internet telephony (voice over IP), presence, instant messaging, and many further application areas. It allows establishing and controlling IP connections between mobile terminals.

HSDPA is a packet-based data service in W-CDMA downlink with maximum user data rates of 10.8 Mbps (and 20 Mbps for MIMO systems) over a 5 MHz bandwidth in W-CDMA downlink [PEM04]. Major performance improvements by HSDPA are achieved by using:

- shorter frame sizes (2 ms transmission time interval),
- multi-code transmission,
- Adaptive Modulation and Coding (AMC) including QPSK and 16-QAM with fast CQI feedback,
- fast scheduling
- fast Hybrid Automatic Repeat Request (HARQ) based on N-Channel Stop-and-Wait Protocol using chase combining or Incremental Redundancy (IR) [DMR02],
- Multiple-Input Multiple-Output (MIMO),
- and advanced receiver design [WCE02].

All Release 99 and Release 4 transport channels are terminated at the RNC. With the introduction of the HSDPA traffic channel (HS-DSCH), parts of the MAC layer (so-called MAC-hs) are moved to the Node B. MAC-hs handles priorities, performs scheduling and directly controls the HARQ protocol. Therefore, scheduling and retransmissions can be performed with less delay. With HSDPA, the Iub interface between Node B and RNC requires flow control and buffer management. The RNC still performs RLC functionalities.

Release 5 (HSDPA) offers a maximum user data rate in the downlink of 10.8 Mbps without MIMO. Spectral efficiency is in the order of 1 to 1.8 bps/Hz/cell/carrier [Jav05] [HT04]. Cell throughput is increased by around 50% in macro cells and up to 100% in micro cells [HT04]. Currently (i.e. in 2006) first HSDPA deployments are already operational.

Considering the notable performance enhancements provided by HSDPA, the key techniques and strategies (fast scheduling, AMC, HARQ) used need also to be carefully investigated in WINNER

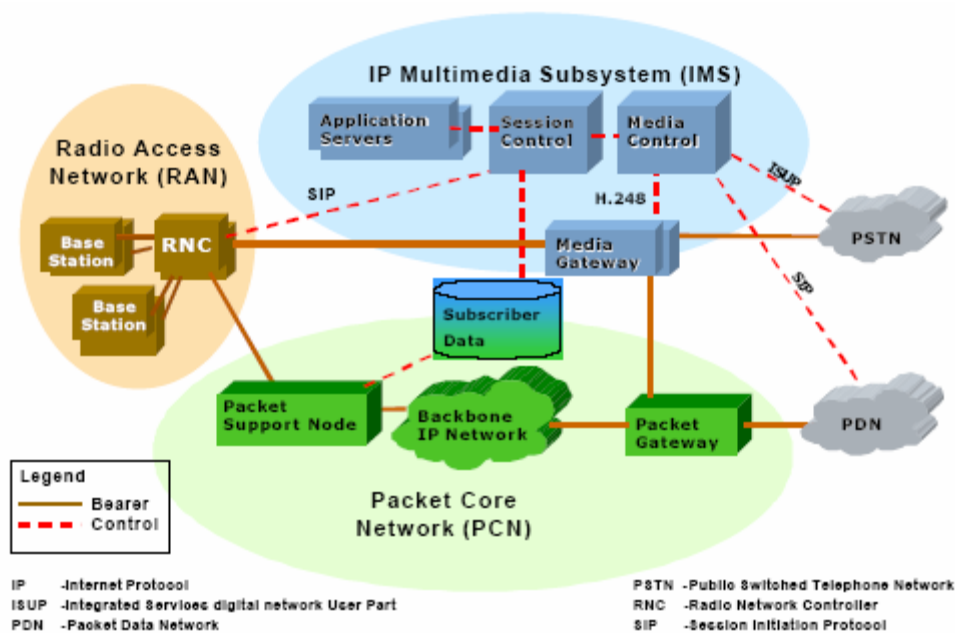

Figure 2-5: Rel.5 specific architecture [3GA04]

2.5 Release 6

Release 6 specifications have been completed in December, 2004 and included main new features like Multimedia Broadcast Multicast Service (MBMS), and High Speed Uplink Packet Access (HSUPA), the second phase of IMS, interworking with WLAN, and further specifications to support advanced receivers.

MBMS is a unidirectional point-to-multipoint IP datacast service that improves efficiency of broadcast and multicast in UMTS. MBMS is a solution for transferring small to medium size video and audio clips, real and high-rate streaming to a large, concentrated audience will consume considerable resources of the UMTS system and often DVB-H is considered as a competing candidate technology. Deployment of MBMS is expected in the years 2007/2008 [TS04].

The MBMS architecture introduces new elements, like the Broadcast Multicast Serving Center (BMSC), which acts as entry point for the content provider, and controls the MBMS service [25.992]. Ciphering is only used in the multicast mode, not in broadcast mode. HARQ is not used. IP packet loss protection is achieved by application layer forward error correction (FEC). The MBMS service can be provided either using point-to-point transmissions (in multicast mode) or point-to-multipoint transmission. The FACH transport channel is used to transmit MBMS data [25.346].

Due to the late integration into the UMTS standard, providing a technical solution within the constraints of maximum re-use of the existing framework and channels for this service has proven to be difficult and leaves room for further enhancements [BB05]. It is therefore recommended that efficient support for

multicast and broadcast services should be an important system design goal for future research in WINNER.

HSUPA will complement the HSDPA to allow symmetrical high-speed data communications, supporting multimedia, VoIP, etc. HSUPA increases the uplink data rates and reduces delays using a new traffic channel, referred to as Enhanced DCH (E-DCH). Improved performance by HSUPA is based on similar technologies as used for HSDPA [UF05] [25.808]:

- Higher-order modulation (16-QAM),
- Shorter frame sizes (2 ms transmission time interval) enabling faster link adaptation,
- fast scheduling,
- fast HARQ with IR.

The HSUPA packet scheduler operates on a request-grant principle where the UE requests permission to send packets and the scheduler decides when and which UEs are granted uplink resources. A request for transmission will contain data about the state of the transmission buffer, the queue at the UE and its available power margin. In addition to scheduled, also self-initiated (low-rate) transmissions from the UE are possible (e.g. VoIP services for which even the reduced TTI and the Node B based scheduler will not be able to provide the very short delay time required). In HSUPA, unlike in HSDPA, soft and softer handovers will be allowed for packet transmissions.

The experience of HSUPA has highlighted the particular problems for fast packet-oriented transmissions with bursty traffic in uplink, when scheduling entity and data source are separate and only connected via wireless connections. Fast, resource-efficient and error-resistant protocols, control channels, as well as design of connection states are still worth further research.

The maximum possible peak data rate for E-DCH is 5.76 Mbps (compared to 384 kbps in uplink provided until Release 5). Around 80% system capacity increase, 50% user throughput increase and 50% reduction in end user packet call delay are expected [25.896] [UF05] [3GA05]

2.6 3GPP Long Term Evolution (LTE)

The Study Item on UTRA Long Term Evolution started early 2005 at 3GPP RAN and is expected to finish in June 2006. Most of the companies involved in Evolved-UTRAN (E-UTRAN) anticipate a deployment around the year 2010. Initial physical layer evaluation results and first conclusions have been completed by 3GPP-RAN1 at RAN1#45, Shanghai, May 8 - 12, 2006. Further studies will occur in the upcoming months. However, the status of presented numbers hereafter is based on the figures presented at RAN1#45.

2.6.1 E-UTRA Deployment Scenarios

The deployment scenarios considered for E-UTRA are essentially urban and suburban (see below). The system will be optimized for low velocities (i.e. below 30 km/h) but shall provide good performance up to 250 km/h [25.913]. For these reference cases two centre frequencies are considered, UMTS core frequency band 2.0 GHz and also the GSM band at 900 MHz.

Table 2-3: Reference deployment for the LTE

Simulation	Carrier Frequency	Inter-Site-Distance	Bandwidth	Penetration Loss	Speed
Cases	(GHz)	(meters)	(MHz)	(dB)	(km/h)
1	2.0	500	10	20	3
2	2.0	500	10	10	30
3	2.0	1732	10	20	3
4	0.9	1000	1.25	10	3

Supported bandwidths are 1.25 MHz, 1.6 MHz, 2.5 MHz, 5 MHz, 10 MHz, 15 MHz, and 20 MHz. The two duplex modes FDD and TDD have been defined in a unified framework. In the unicast case, the assumption on the network is asynchronous base stations. Synchronous Single Frequency Network (SFN) is also studied for multi-cast/broadcast

2.6.2 E-UTRA key features

Details of the physical layer as currently considered by 3GPP RAN WG1 can be found in [25.814]. In the following we give a short summary of the main features.

2.6.2.1 Downlink

The downlink is based on OFDMA allowing a high flexibility in the resource allocation and scalability for the different considered bandwidths. The transmission time interval (sub-frame) is further reduced compared to HSDPA to 0.5 ms, which ensures low latency and enables fast packet scheduling. Longer transmission intervals are considered for specific services. The supported downlink data-modulation schemes are QPSK, 16QAM, and 64QAM.

Packet scheduling operates on a sub-frame basis of 0.5 ms in time and optionally in frequency. The scheduler allocates resource blocks consisting of a set of time/frequency positions in the OFDM sub-frame. Either consecutive (localized) or non-consecutive (scattered, distributed) subcarriers/time positions are supported. Scheduling is based on a report of a channel quality indicator measured by the mobile. It is assumed that several such indicators per sub-frame are fed back by the terminal for different sub-bands to enable frequency selective scheduling.

Link adaptation is applied to the shared data channel. The same coding and modulation is applied to all groups of resource blocks belonging to the same coded block scheduled to one user within one sub-frame and within a single stream. This applies to both localized and distributed transmission.

The baseline antenna configuration for MIMO and antenna diversity is two transmit antennas at the cell site and two receive antennas at the terminal. The higher-order downlink MIMO and antenna diversity (four TX and two or four RX antennas) is also supported. Transmit diversity as well as single and multi-user MIMO schemes with pre-coding are considered. For control channels, only single stream using the multiple transmit antennas is supported.

Interference coordination among cells with static and semi-dynamic schemes (update of scheduler restrictions within tens of seconds or more) is also considered as a key feature to improve cell edge performance. The basic principle is to impose restrictions to the scheduler decisions in the different sub-bands. A typical restriction in the downlink is the maximum transmit power for each sub-band. In this way fractional frequency re-use factors are obtained ranging typically from 1 – 3. In static schemes the power restrictions are done during the network planning phase and are not dynamically updated. In semi-static schemes updates are supported, for example, to adapt to varying system loads in different cells.

2.6.2.2 Uplink

The uplink transmission scheme is based on low-PAPR single-carrier transmission (SC-FDMA) with cyclic prefix to achieve uplink inter-user orthogonality and to enable efficient frequency-domain equalization at the receiver side. The transmission time interval (sub-frame) is 0.5 ms identical to the downlink. Longer transmission intervals are considered for specific services.

SC-FDMA modulation is performed using DFT pre-coded OFDM modulation as shown in Figure 2-6. The subcarrier mapping determines which part of the spectrum is used for transmission by inserting a suitable number of zeros at the upper and/or lower band edge (cf. Figure 2-7). Between each DFT output sample $L-1$ zeros are inserted. A mapping with $L=1$ corresponds to localized transmissions, i.e., transmissions where the DFT outputs are mapped to consecutive subcarriers. With $L>1$, distributed transmissions are achieved, which are considered as a complement to localized transmissions for additional frequency diversity. Frequency adaptive scheduling is supported in the uplink with localised resources.

The baseline antenna configuration for uplink single-user MIMO is two transmit antennas at the UE and two receive antennas at the cell site. If the UE has only a single power amplifier and two transmit antennas, the antenna switching/selection is the only option that is supported for SU-MIMO. To allow for MU-MIMO reception at the Node B, allocation of the same time and frequency resource to two UEs, each of which transmitting on a single antenna, is supported as part of the uplink baseline configuration.

Interference coordination among cells is also considered in the uplink. Note that the slow power control applied can be exploited also for interference mitigation.

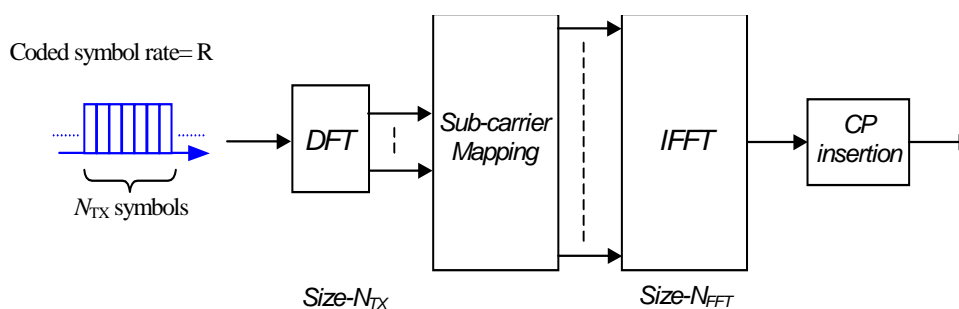

Figure 2-6: Transmitter structure for SC-FDMA in E-UTRA

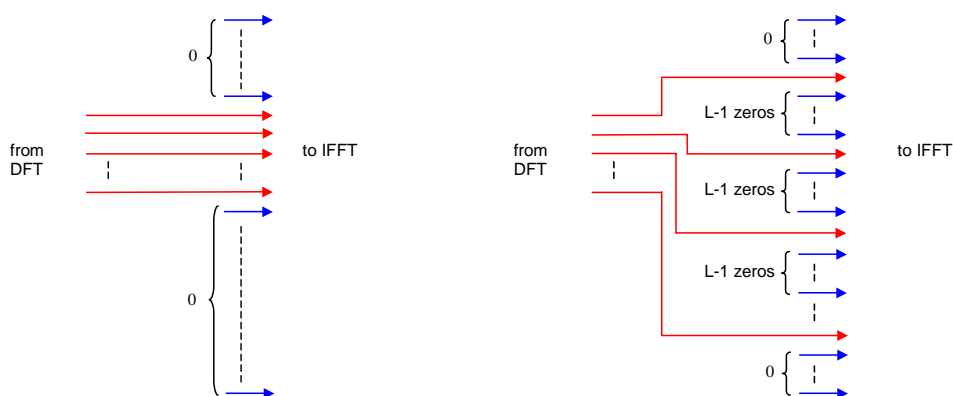

Figure 2-7: Localized mapping (left) and distributed mapping (right) in E-UTRA

2.6.3 Expected Performance of E-UTRA

Target requirements for E-UTRA are defined in [25.913]. Throughout the following, focus is put on evaluation of peak data rate, spectrum efficiency, user and cell edge throughput, as well as user plane latency. The given numbers are based on the results presented at RAN1#45, Shanghai, May 8 - 12, 2006. Further studies will occur in the upcoming months.

2.6.3.1 Peak Data Rates

The expected peak data rates for E-UTRA are captured in Table 2-1 below. This performance is based on agreed parameter sets at 3GPP RAN WG1 level. The peak cell throughput is calculated including frame structure, modulation, coding, and overhead. In Table 2-4, the baseline overhead refers to overhead already identified with the parameters given in [25.814] such as cyclic prefix, guard time, guard carriers and reference symbols. The full overhead includes an estimation of the additional overhead essentially coming from L1/L2 signalling (e.g. scheduling information, HARQ, and CQI measurement reports). These results show that the initial requirements [25.913] for the cell throughput may be approached both on the downlink and on the uplink. As use of multiple antennas is assumed on the downlink it is even possible to exceed the initial peak rate requirements.

Table 2-4: E-UTRA peak data rates

	Downlink		Uplink	
Assumptions	2 TX MIMO, 64QAM, R=1 10% reference signal overhead		Single TX UE, 16 QAM, R=1 14% reference signal overhead	
Unit	Mbps in 20 MHz	b/s/Hz	Mbps in 20 MHz	b/s/Hz
Target Requirement	100	5.0	50	2.5
Baseline overhead (cyclic prefix, guard time, guard carriers and reference symbols)	182	9.1	57	2.9
Full overhead (29% total system and L1/L2 signalling overhead)	144	7.2	48	2.4

2.6.3.2 Spectrum Efficiency and User Throughput

In [25.913] the requirements in terms of spectral efficiency and throughput have been defined as relative requirements compared to Release 6's HSDPA and HSUPA spectrum efficiencies.

Requirements for spectrum efficiencies are given with respect to Release 6 HSDPA using a single antenna at base station and terminal which uses a Rake receiver. The expected improvements provided by E-UTRA are summarised in Table 2-5 and Table 2-6 for deployment case 1 of Table 2-3 (which corresponds to the low mobility case and a deployment at 2 GHz). Note that, while the relative gains obtained by different source companies seem to converge to some extent, the absolute values depend on simulation assumptions (especially the considered system load), which are very different among companies. Absolute normalized sector, average user and 5%ile user throughput values for 3GPP Release 6 given in [25.913] for case 1 deployment lie in the range of 0.44 – 0.988 bit/s/Hz, 0.026 – 0.42 bit/s/Hz and 0.006 – 0.14 bit/s/Hz, respectively, for the downlink and 0.17 – 0.46 bit/s/Hz, 0.02 – 0.13 bit/s/Hz and 0.0051 – 0.075 bit/s/Hz, respectively, for the uplink. The absolute numbers for the uplink are given without multi-user MIMO (SDMA). The current results simultaneously meet both uplink requirements in most cases. Results on the performance of interference coordination schemes are also missing in the uplink.

According to current results, it is not guaranteed that the downlink targets are simultaneously met. It can also be noted that there is a lack on evaluation results for interference coordination and MIMO schemes.

Table 2-5: E-UTRA downlink performance

	Target	Relative gain achieved	Absolute values bits/s/Hz
Average spectral efficiency	3x – 4x	2.5x – 3.2x	up to 2.6 (2x2 MIMO)
Cell edge spectral efficiency per user (5% point of the user throughput CDF)	2x – 3x	2x – around 3x	up to 0.27

Table 2-6: E-UTRA uplink performance

	Target	Relative gain achieved	Absolute values bits/s/Hz
Average spectral efficiency	2x – 3x	2.1x – more than 3x	up to 0.9
Cell edge spectral efficiency per user (5% point of the user throughput CDF)	2x – 3x	2x – more than 3x	up to 0.15

2.6.3.3 User Plane Latency

Very low user plane latency is a crucial system property for future packet-switched mobile communications systems since particularly IP-based protocols such as TCP/IP react rather sensitive on long delays for packet acknowledgments. Hence user plane latency should be carefully taken into account when designing the WINNER channel structure, scheduling and ARQ schemes.

The user plane latency can be defined as the one-way transit time between a packet being available at the IP layer in either the terminal or the access gateway and the availability of this packet at IP layer in the access gateway or the terminal. An assessment of the expected user plane latency can be found in [25.912]. The results are summarised in the following Table 2-7. An average delay of 4.0 ms (including the transfer delay between base station and gateway) is achievable with the current E-UTRA protocol design [25.814]. Reducing the user plane latency to values lower than 1 ms is a crucial design goal for the WINNER system.

Table 2-7: Assessment of U-plane latency

Step	Description	Value
0	Terminal wakeup time	Implementation dependent – Not included
1	Terminal Processing Delay	1 ms
2	Frame Alignment	0.25 ms

Step	Description	Value
3	Sub-frame duration for UL data packet (Piggy back scheduling information)	0.5 ms
4	HARQ Retransmission (@ 30%) (N=5 stop-and-wait protocol)	0.3*2.5 ms
5	Base station Processing Delay	1 ms
6	Transfer delay between base station and	Ts1u (1 ms – 15 ms)
7	Gateway processing delay	0.5 ms
	Total one way delay	4 ms + Ts1u

3. 3GPP 2 Standards

The 3rd Generation Partnership Project 2 (3GPP2) like its sister project 3GPP (see previous section) is a collaborative effort between Standards Development Organizations known as Organizational Partners.: ARIB – Japan, CCSA – China, TIA – North America, TTA – Korea and TTC – Japan.

In addition the project has welcomed Market Representation Partners falling within the 3GPP2 scope: The CDMA Development Group, the IPv6 Forum and the International 450 Association.

The concept of partnership project was pioneered by the ETSI with the creation of the 3GPP focusing on the evolution of the GSM technology (see previous section). The 3GPP2 was created to develop global specifications for ANSI / TIA / EIA-41 Cellular Radiocommunication Intersystem Operations network evolution to 3G and the supported radio transmission technologies.

The 3GPP2 Technical Specification Group Access Network Interfaces (TSG-A) is responsible for the specifications of interfaces between the radio access network and core network, as well as within the Access Network. The TSG-A addresses the following areas of work: physical links, transports and signalling; support for access network mobility; 3G capability (e.g., high speed data support); Abis interface; inter-operability specification; support for 3GPP2 Radio Access technologies

The 3GPP2 Technical Specification Group cdma2000[®] (TSG-C) is responsible for the radio access part, including its internal structure, of systems based on 3GPP2 specifications. The TSG-C addresses the following areas of work: Radio Layer 1 specifications; Radio Layer 2 specifications; Radio Layer 3 specifications; MS/BS radio performance specifications; Radio link protocol; Support for enhanced privacy, authentication and encryption; Digital Speech Codecs and related minimum performance specifications; Video Codec selection and specification of related video services; Data and other ancillary services support; Conformance test plans; Removable User Identity Module (R-UIM); Location-based services support.

3.1 3GPP2 1xEV-DO

Throughout the following 3GPP2 enhancements 1xEV-DO Rev. A to C are highlighted by providing an overview of the major properties and targeted throughout. The information given in this section is on rather high level since the development of particularly 1xEV-DO Revision C is still ongoing. Progress in 3GPP2 might require a better coverage of these activities in the next issue of this deliverable.

3.1.1 3GPP2 1xEV-DO Revision A

The purpose of Revision A is higher downlink and uplink peak data rates, and lower system latencies to support delay-sensitive applications. With Rev. A, operators will be able to introduce advanced multimedia services, including voice, data and broadcast over all-IP networks.

Revision A is designed for a 1.25 MHz band as used in CDMA2000 up to now. The peak bit rates are 3.1 Mbps for the uplink and 1.8 Mbps for the downlink. QoS is improved over Release 0. Lower latency, prioritization of low-latency applications and QoS software enhancements added to Revision A improve performance of delay-sensitive applications such as VoIP, push-to-talk, instant messaging and video

telephony. Revision A QoS allows greater control over network resources. According to the CDMA Development Group (CDG)¹, Revision A services will be commercial in early 2007.

3.1.2 3GPP2 1xEV-DO Revision B (DO Multicarrier)

This standard is finalized now.² Revision B adds scalable bandwidth, i.e. logically adds up to 15 EV-DO Revision A carriers (1.25 MHz bandwidth each) above the PHY layer. Thus the maximum bandwidth is 20 MHz. The targeted peak data rate is 73.5 Mbps on the downlink (forward link) and 27 Mbps on the uplink (reverse link). A single 1.25 MHz carrier will deliver a peak downlink data rate of 4.9 Mbps. It is stated that no new hardware has to be developed, i.e. software upgrades are sufficient. However, some optional new features were added to increase peak data rate and throughput. Among them is the addition of 64QAM modulation.

Revision B will be commercially available in 2008 according to CDG.

3.1.3 3GPP2 1xEV-DO Revision C

This revision is currently in discussion. Multi-antenna technologies (MIMO, SDMA, precoding, beamforming), flexible channel bandwidths of 1.25/5/10 and 20 MHz, H-ARQ, 64QAM, frequency-selective scheduling as well as the use of OFDM/OFDMA are discussed in proposals from different vendors and consortia. The proposals differ mainly in the grade of backwards compatibility.

The proposals for Revision C will have very likely some similarities to WINNER II since they capture the current state-of-the-art. It is important for WINNER to monitor these activities in the future, and to benchmark the WINNER system concept against the evolved 3GPP2 system, which will likely provide flexibility, high throughput and low delay.

4. IEEE Standards

The wireless standardisation in IEEE happens in the IEEE 802 LAN/MAN standards committee. Under this committee there are several working groups focusing from short range communications to wide area wireless communications systems. The working groups mostly relevant from WINNER II point-of-view are listed below.

4.1 IEEE 802.11 Wireless LAN

The IEEE 802.11 Working Group provides Wireless Local Area network (WLAN) standards. The basic standard was developed in 1999 [802.11], further enhancements are provided as amendments to the standard which are developed in numerous task groups. The task groups are referred to with different letters, currently going up to 'y' which is dealing with 3650-3700 MHz operation in the USA.

For the PHY layer several options exist, IEEE 802.11a is the WLAN standard operating in the 5 GHz band, the air interface is based on Orthogonal Frequency Division Multiplexing (OFDM) with a maximum data rate of 54 Mbps. IEEE 802.11b is the standard operating in the 2.4 GHz band based on Direct Sequence Spread Spectrum (DSSS) and Complementary Code Keying (CCK) and provides data rates up to 11 Mbps. IEEE 802.11g operates in the 2.4 GHz band, but is also based on OFDM and provides 54 Mbps. Currently most commercially available WLAN products are either based on the IEEE 802.11b or g standard, the main characteristics of the different physical layer options are tabulated in Table 4-1.

Table 4-1 Comparison of the different WLAN PHY layer options

	IEEE 802.11a: High-speed PHY layer in the 5 GHz band	IEEE 802.11b: High-speed PHY layer extension in the 2.4 GHz band	IEEE 802.11g: Further Higher Data Rate extension in the 2.4 GHz band	IEEE 802.11n: Enhancements for Higher Throughput
Year of approval	1999	1999	2003	unapproved
Modulation	OFDM	DSSS, CCK	OFDM, CCK, OFDM	OFDM, CCK, OFDM

¹ <http://www.cdg.org/technology/3g/evolution.asp>

² 3GPP2 C.S0024-B, TIA/EIA/IS-856-B

RF band	5 GHz	2.4 GHz	2.4 GHz	2.4 and 5 GHz
Channel width	20 MHz	20 MHz	20 MHz	20 MHz only and 20/40 MHz
Max data rate	54 Mbps	11 Mbps	54 Mbps	600 Mbps

The basic medium access protocol is the Distributed Coordination Function (DCF) which allows for medium sharing based on a “listen before transmit” scheme using Carrier Sense Multiple Access with Collision Avoidance (CSMA/CA). Before transmitting the channel is sensed for the duration of an inter-frame space (in this case called Distributed Inter-Frame Space (DIFS)), if the channel is available the frame is transmitted; if the channel is busy the transmission is deferred until the channel becomes available again. Before transmitting a deferred frame back-off is applied to prevent collisions, i.e. a random value within the Contention Window (CW) is selected, this value is decremented while scanning the channel, if the value reaches zero and the channel is still idle the frame is transmitted [802.11]. The scheme is illustrated in Figure 4-1. In case of a retransmission the backoff window is exponentially increased. Additional protection of the transmission can be provided with RTS/CTS signalling which prohibits transmissions in the areas around the transmitter and receiver for the duration of the transmission. Besides the mandatory contention-based channel access scheme (DCF), the standard also introduces an optional centrally controlled channel access scheme referred to as Point Coordination Function (PCF)

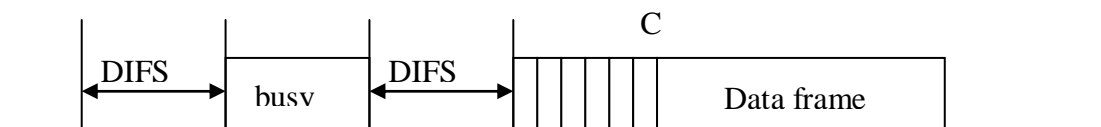

Figure 4-1 Channel access using CSMA/CA, channel access is immediate after DIFS if the medium is not busy.

The basic standard distinguishes two main entities: stations (STA) and Access Points (AP), which can operate in two modes: infrastructure and ad-hoc. The infrastructure mode is a star topology of stations connected to an AP, and the ad-hoc mode consists of peer-to-peer connections between stations. An AP serving a certain area is referred to as a Basic Service Set (BSS), using a Distribution System (DS) several APs can be interconnected to form an Extended Service Set (ESS). A BSS operated without DS (in ad-hoc mode) is referred to as an independent BSS.

Inter-operability and testing issues of the IEEE 802.11 standard are addressed by the WiFi alliance, which is short for “Wireless Fidelity” alliance. WiFi certification assures proven and tested interoperability between different WLAN devices. The WiFi alliance is independent from the IEEE 802.11 standardization body.

Of the different enhancements to the basic standard (IEEE 802.11a/b and g) the most relevant ones for the WINNER system are, QoS enhancements (.11e), enhancements for higher throughput (.11n) and mesh networking (.11s) enhancements. Other amendments include enhancement related to security (.11i), radio resource measurements (11k), and fast roaming (.11r).

4.1.1 Medium Access Control Quality of Service Enhancements (IEEE 802.11e)

The enhancements developed within the standard are a set of technologies for prioritizing packets and preventing packet collisions and delays. The QoS related enhancements were approved in September 2005 [802.11e]. The standard provides two main channel access mechanisms: Enhanced Distributed Channel Access (EDCA) and HCF Controlled Channel Access (HCCA).

EDCA provides a prioritized CSMA/CA access mechanism. This access mechanism is used by QoS stations in a QoS basic service set, and is also used by the QoS access points. Four traffic classes are distinguished: Background, Best-effort, Video, and Voice. For each of these classes different medium access parameters can be set, using different CW sizes and inter-frame spaces (called Arbitrary Inter-frame space). In the contention process the station contends for a Transmission Opportunity (TxOP) during which one or multiple frames may be transmitted. Multiple frames may be transmitted in case the TxOP limit duration values have not expired after a frame transmission has been completed. The TxOP limit values are advertised in the beacon messages of the access point. EDCA operates concurrently with the Hybrid Coordination Function (HCF) controlled channel access (HCCA). HCCA is the channel access

mechanism that provides contention-free medium access for QoS stations. Under HCCA operation transmission opportunities for the different traffic classes are scheduled to meet their QoS requirements.

Further, the standard also provides special signalling to communicate QoS characteristics for a connection. This signalling is known as Traffic Specification (TSPEC) signalling.

4.1.2 Enhancements for Higher Throughput (IEEE 802.11n)

The basic PHY solutions are currently enhanced within IEEE 802.11n, the High Throughput (HT) Task Group, which targets significant data throughput performance improvements when compared to earlier standards versions [802.11n]. Measured above the MAC (MAC data Service Access Point) the IEEE 802.11n standard should provide a mandatory data rate of 100 Mbps, the maximum PHY data rate with optional features is claimed to be 600 Mbps.

The High Throughput Study Group was established in July 2002, becoming an official Task Group in September 2003. For a long time, no progress was made in IEEE 802.11n, but a joint proposal was approved in January 2006. The release of the IEEE 802.11n standards amendment can be expected in the beginning of 2007, and “pre-n” products were already announced by several vendors. It remains, however open if the products can meet the advertised performance figures and are compatible to each other.

IEEE 802.11n is based on OFDM and introduces new PHY and MAC layer enhancements. The HT OFDM PHY is based on the OFDM PHY as defined for IEEE 802.11a extended with 2-4 spatial streams operating with 20 MHz bandwidth and further extended with 40 MHz operation using 1-4 spatial streams. Other features of the PHY are the use of Low-Density Parity-Check (LDPC) codes, parallel use of encoders, flexible guard band length, MIMO support (spatial multiplexing, space-time block coding, transmit beamforming and space time block codes).

Table 4-2 presents some of the most important timing related constants for the different modes of the HT standard. In the case of a non-HT mode and HT mode transmission over a 20MHz channel, the channel is divided into 64 subcarriers. In the non-HT mode the signal is transmitted on subcarriers -26 to -1 and 1 to 26, with 0 being the center (DC) carrier. In the HT modes the signal is transmitted on subcarriers -28 to -1 and 1 to 28. In the case of a 40 MHz HT transmission, two adjacent 20 MHz channels are used. The channel is divided into 128 subcarriers. The signal is transmitted on subcarriers -58 to -2 and 2 to 58. In the case of the non-HT duplicate mode over 40 MHz, the same data are transmitted over two adjacent 20 MHz channels. In this case the 40 MHz channel is divided into 128 subcarriers and the data are transmitted on subcarriers -58 to -6 and 6 to 58. For example RTS messages, CTS-to-self, CTS response, and certain acknowledgements may be transmitted in non-HT duplicate mode to ensure that devices operating at 20 MHz bandwidth can also receive them.

Table 4-2 Salient Timing related constants.

Parameter	Non-HT 20 MHz channel	HT 20 MHz channel	40 MHz channel	
			HT format	Non-HT duplicate
Number of data subcarriers	48	52	108	48
Number of pilot subcarriers	4	4	6	4
Total number of subcarriers	52	56	114	
Subcarrier spacing (Δ)	312.5 kHz (20 MHz / 64)	312.5 kHz	312.5 kHz (40 MHz / 128)	
IFFT/FFT period (T _{FFT})	3.2 μ s	3.2 μ s	3.2 μ s	
Guard Interval length (TGI)	0.8 μ s (T _{FFT} /4)	0.8 μ s	0.8 μ s	
Short Guard interval length (TGI ₂)	0.4 μ s	0.4 μ s	0.4 μ s	
Symbol Interval	4 μ s (T _{FFT} +T _{GI})	4 μ s	4 μ s	
Short Symbol Interval	3.6 μ s (T _{FFT} +T _{GI₂})	3.6 μ s	3.6 μ s	

The MAC enhancements of IEEE 802.11n mainly aim at the reduction of overhead, and include frame aggregation mechanisms, block acknowledgements, MIMO power save support and a reduced Inter-Frame Space (RIFS). The Quality-of-Service support is based on IEEE 802.11e.

Frame Aggregation: The main idea of frame aggregation is to aggregate multiple frames into a single transmission opportunity. Aggregation results in reduced overhead: less headers, channel contention and acknowledgements. The standard also provides additional protection mechanisms to protect aggregated transmission. Care should be taken not to generate jumbo packets, the proposed aggregation mechanism require that the frame sizes are less than the fragmentation threshold.

Block Acknowledgements: The Block ACK mechanism improves the channel efficiency by aggregating several ACKs in one frame. The use of Block ACK is negotiated using TSPEC signalling. The mechanism was introduced in IEEE 802.11e and is used further in IEEE 802.11n.

MIMO power-save: A MIMO device consumes power in all the active Rx chains, the MIMO power-save feature allows the station to have most of the time only one Rx chain active. Only when the station receives a sequence directed to it, it enables multiple Rx chains. This means that such a sequence should always start with a single-spatial stream frame (this could for example be a RTS frame), the station switches back to the mode with one active Rx chain immediately after the TxOP ends. This mechanism ensures that only during active reception all Rx chains have to be active.

Reduced Inter-Frame Space: RIFS may be used to replace the Short Inter-Frame Space when separating multiple transmissions from a single transmitted. This is mainly a means to reduce the overhead and increase the network efficiency.

Other MAC extensions include: transmit beamforming, antenna selection, link adaptation, and new signalling for bandwidth switching.

4.1.3 Mesh Networking (IEEE 802.11s)

Another active IEEE 802.11 Task Group which is relevant for WINNER is 802.11s (ESS Mesh Networking), which is specifying a mesh networking solution for 802.11 radios. In 2005, several consortia made different proposals, but in early 2006 it was agreed on one joint proposal [802.11s] [Fac06]. The standard is aimed to be approved mid 2008.

The 802.11 TGs defines an Extended Service Set (ESS) Mesh (here referred to as mesh network) as a collection of WLAN devices interconnected with wireless links that enable automatic topology learning and dynamic path configuration. 802.11 mesh networks will be based on extensions to the IEEE 802.11 MAC standard, based on the definition of mesh network architecture and new protocol mechanisms. The architecture will provide an IEEE 802.11 wireless DS that supports both broadcast/multicast and unicast delivery at the MAC layer using radio-aware metrics over self-configuring multi-hop topologies, thus providing the functional equivalent of a wired DS. The mesh standard will allow for fully meshed, ad-hoc network type operation using WLAN devices.

4.2 IEEE 802.16 Broadband Wireless Access

The IEEE 802.16 Working Group on Broadband Wireless Access Standards develops standards and recommended practices to support the development of broadband Wireless Metropolitan Area Networks. The early standard versions were intended for fixed wireless solutions. In February 2006 the first standards version supporting mobility (at physical layer, hand-over, security), i.e. IEEE 802.16e [802.16e], was published.

Currently active TGs in 802.16 include:

- 802.16f and 802.16g which deal with Network Management Information Base (MIB) and Management Plane Procedures and Services, respectively
- 802.16h is developing improved mechanisms (as policies) and MAC enhancements to enable coexistence among license-exempt systems based on 802.16 standards and facilitates the coexistence of such systems with primary users of the spectrum
- 802.16i is a continuation of 802.16f, focusing on mobility enhancements in the network management
- 802.16j has been created from the IEEE 802.16 Mobile Multi-hop Relay (MMR) Networking Study Group in early 2006. The aim is to enhance the PHY frame structure and to add new MAC protocols to support relaying. Cooperative relaying and multipath diversity are also considered. This TG is of high relevancy to WINNER since it tries to support relaying for the metropolitan area.

The most relevant standard from WINNER perspective in 802.16 family, however, is 802.16e.

4.2.1 Physical Layer Properties of IEEE 802.16e

Physical layer of IEEE 802.16e [802.16e] is based on OFDMA, supporting TDD, FDD and half-duplex FDD. The OFDMA symbol has three types of subcarriers: data subcarriers for data transmission, pilot subcarriers for channel estimation and synchronization, and null subcarriers used for guard bands and DC carriers. Data and pilot subcarriers are organized to sub-channels, with minimum frequency-time resource unit of one slot consisting of 48 data tones (subcarriers). The sub-channel permutations are based on diversity or contiguous arrangement of subcarriers belonging to same sub-channel. The sub-channels can occupy only a fraction of whole bandwidth. This can be utilized in accommodating fractional frequency re-use. Moreover, it is possible to split users into groups, so that users close to a base station can use all sub-channels, whereas users near to the cell border use only a subset of the whole bandwidth.

The OFDMA scheme is designed to be scalable in order to support a wide range of bandwidths in order to support different spectrum allocation and use case requirements. Moreover, the TDD mode enables adjustment of uplink-downlink ratio for asynchronous traffic.

Adaptive modulation and coding, hybrid ARQ and fast channel feedback were introduced in 802.16e. Multiple antenna technologies are supported, including beamforming, space-time codes and spatial multiplexing.

4.2.2 Performance of IEEE 802.16e

The PHY data rates for available modulation and coding schemes in 802.16e with Partially Used Sub-Channel (PUSC) are summarized in Table 4-3. The optional uplink 64QAM rates are highlighted with yellow. The simulative performance evaluation results for 802.16e can be found from [WiMAX], the achievable spectral efficiency is for uplink 0.55-0.83 b/s/Hz and for downlink 1.09-1.87 b/s/Hz. The results are based on semi-static simulations with full buffer traffic model and proportional fair scheduling. Moreover, ideal channel estimation is assumed. These assumptions can lead to somewhat optimistic results.

Table 4-3: PHY data rates for Mobile WiMAX with PUSC channel for 5 MHz and 10 MHz bandwidth

Mod.	Code Rate	5 MHz Channel		10 MHz Channel	
		Downlink Rate / Mbps	Uplink Rate / Mbps	Downlink Rate / Mbps	Uplink Rate / Mbps
QPSK	1/2 CTC, 6x	0.53	0.38	1.06	0.78
	1/2 CTC, 4x	0.79	0.57	1.58	1.18
	1/2 CTC, 2x	1.58	1.14	3.17	2.35
	1/2 CTC, 1x	3.17	2.28	6.34	4.70
	3/4 CTC	4.75	3.43	9.50	7.06
16 QAM	1/2 CTC	6.34	4.57	12.07	9.41
	3/4 CTC	9.50	6.85	19.01	14.11
64QAM	1/2 CTC	9.50	6.85	19.01	14.11
	2/3 CTC	12.67	9.14	26.34	18.82
	3/4 CTC	14.26	10.28	28.51	21.17
	5/6 CTC	15.84	11.42	31.68	23.52

4.2.3 Deployment Options and WiMAX Profiles

Mobile WiMAX is intended to support a very wide range of deployment scenarios, from providing affordable internet access in rural setting, to enhancing capacity for urban wireless broadband access. Mobile WiMAX will be using licensed bands in 2.3, 2.5 and 3.5 GHz range. Bandwidths are scalable from 1.25 MHz to 20 MHz, but in Release 1 supported profiles are 5 MHz, 7 MHz, 8.75 MHz, 10 MHz, and 20 MHz. The duplexing in the Release 1 profiles is based solely on TDD, and the multiple access on OFDMA. The only mandatory subcarrier permutation scheme is PUSC, other permutations defined in the 802.16e standard are optional.

4.2.4 WiMAX Network Architecture

IEEE has only defined PHY and MAC layers in the 802.16 standard. The WiMAX forum has initiated two working groups in order to develop standard network reference models for an open inter-network interfaces. The Network Working Group is developing high level networking specifications for fixed, nomadic, portable and mobile WiMAX systems. The Service Provider Working Group helps defining and prioritizing requirements in order to drive the NWG work.

The network architecture is based on packet switched access Figure 4-2. The elements of the connectivity system are agnostic to 802.16 radio specifics, all WiMAX flavours and deployments are supported. The connectivity network will provide network inter-working and roaming, security, mobility and handovers to other networks and other technologies. Multi-vendor operability is one of the key aspects of the architecture. QoS will be supported as well.

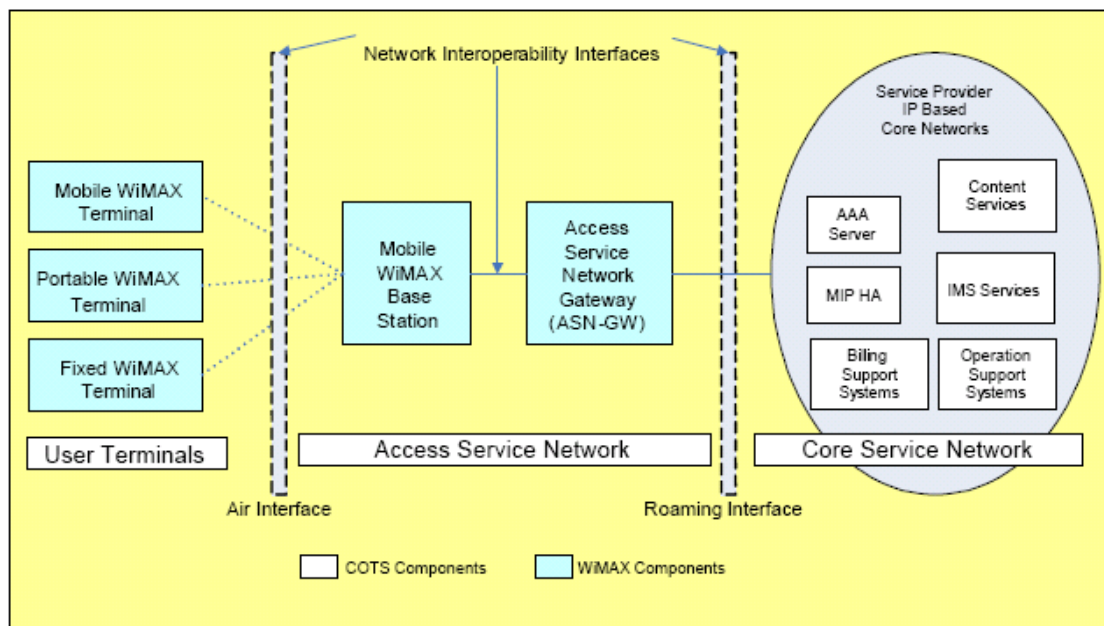

Figure 4-2: WiMAX Network IP-based Architecture [WiMAX]

4.2.5 Timescale

Mobile WiMAX Release-I profile certification is expected by 3Q 2006, and the roll-out of Mobile-WiMAX products is expected during 2006.

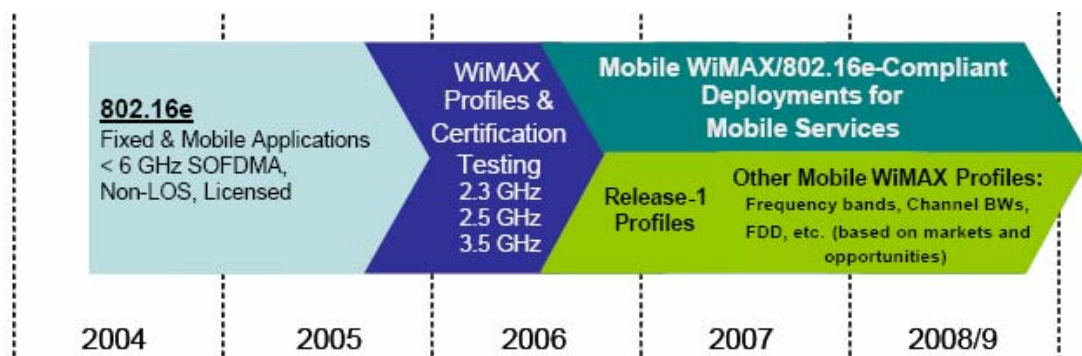

Figure 4-3: WiMAX deployment Timeframe

4.3 IEEE 802.20 Mobile Broadband Wireless Access

The IEEE 802.20 Working Group deals with the ‘Mobile Wireless Interface’ for cellular type of system targeting both nomadic and mobile users at home or in work (see Figure 4-4)., The aim of IEEE 802.20 is

to specify PHY and MAC for interoperable mobile broadband wireless access systems optimized for IP-data transport. The peak user data rates should be in excess of 1 Mbps in the downlink, and 300 kbps in the uplink. Targets for the peak aggregate data rates per cell are 4 Mbps and 800 kbps for downlink and uplink, respectively. The peak spectral efficiency per sector is defined to be 3.6 b/s/Hz/sector in the downlink, and 1.8 b/s/Hz/sector in the uplink. The target sustained spectral efficiency is in excess of 1 b/s/Hz/sector. The target spectral efficiencies are elaborated further in Table 4-4. IEEE 802.20 shall support vehicular mobility up to 250 km/h. Low latencies are also targeted; the over-the-air MAC frame roundtrip time shall be below 10 ms.

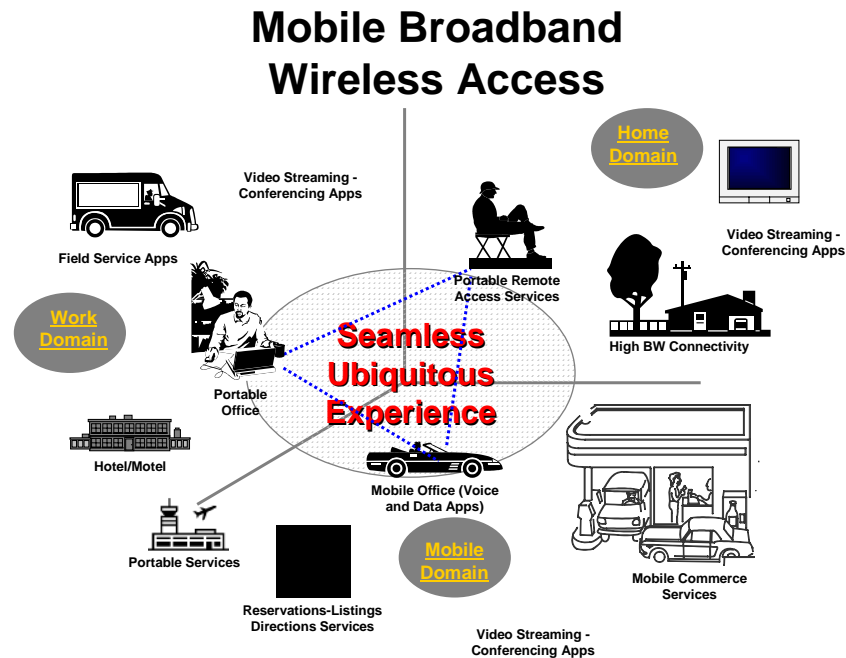

Figure 4-4: Use cases for IEEE 802.20 [802.20]

IEEE 802.20 systems are intended to provide wireless access in a cellular architecture, covering macro-, micro-, and pico-cells (cf. Figure 4-5). For indoor pico-cells, the coverage is intended to be provided by outdoor system deployments. The systems shall be operating in licensed frequency bands below 3.5 GHz. FDD and TDD duplex modes are supported. The bandwidths can range from 2×1.25 MHz to 2×20 MHz with FDD, and from 2.5 MHz to 40 MHz with TDD. The obtainable cell sizes are expected to be suitable for ubiquitous metropolitan area networks, and capable of reusing existing infrastructure sites. Table 4-4 summarizes the target spectral efficiency requirements for IEEE 802.20

The working group has been in existence already since December 2002, and compared to other IEEE working groups its' progress has been slow. This has been due to conflicting interests and difference of opinions between different working group partners on technical details and procedural issues. This has prevented the consensus building within the working group, which is required for decision making and progressing the work. Currently the working group is trying to prolong its' duration by trying to extend its' PAR (Project Authorization Request).

Since autumn 2005 IEEE 802.20 seems to have gained some pace as complete system concept proposals for FDD and TDD (called Mobile Broadband FDD "MBFDD" and Mobile Broadband TDD "MBTDD") were submitted to the working group, which increased the coherence of discussions in the working group. These proposals are based on OFDMA with CDMA used for some uplink control channels. MIMO, (including spatial multiplexing, SDMA, beamforming, and precoding), sub-band scheduling, frequency hopping, HARQ, turbo-coding, and 64QAM are among the features that are supported by these proposals.

Table 4-4: IEEE 802.20 spectral efficiencies requirements

Parameter	Spectral Efficiency Requirements			
	Downlink		Uplink	
	3 km/h	120 km/h	3 km/h	120 km/h
Spectral Efficiency (b/s/Hz/sector)	2.0	1.5	1.0	0.75

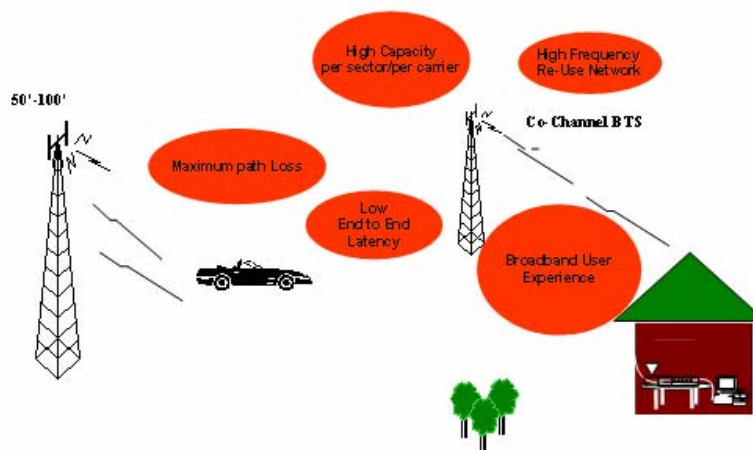

Figure 4-5: Service attributes of IEEE 802.20 based systems

Currently nothing concrete can be said about the timelines of IEEE 802.20 at the moment the extension of the PAR is still under process and detailed technical discussions on the MBFDD and MBTDD proposals are ongoing. As the targets and some of the proposed technical solutions of IEEE 802.20 are closely related to WINNER system targets, especially when thinking about wide area and metropolitan area concept groups, the ongoing activities within IEEE 802.20 should be monitored carefully further.

4.4 IEEE 802.21 Media Independent Handoff

The IEEE 802.21 Working Group is developing standards to enable handover and interoperability between heterogeneous network types including both 802 and non 802 networks. This standardisation work defines extensible 802 media access independent mechanisms that enable the optimisation of handover between heterogeneous 802 systems and may facilitate handover between 802 systems and cellular systems. The purpose is to improve the user experience of mobile devices by facilitating handover between 802 networks whether or not they are of different media types, including both wired and wireless, where handover is not otherwise defined and to make it possible for mobile devices to perform seamless handover where the network environment supports it. These mechanisms may also be useable for handovers between 802 networks and non 802 networks.

The PAR for this working group was approved in November 2003, so it is expected that it finalises its' work in late 2007 or 2008.

4.5 Relevance of IEEE Standards for Benchmarking the WINNER System

IEEE 802.11n higher throughput enhancement aims at providing 100 Mbps above the MAC layer Service Access Point, which has to be significantly exceeded by the WINNER solution for Local Area deployment. Mobility support of IEEE 802.16 was limited in the past but IEEE 16e evolves towards a fully fledged mobile radio system. IEEE 802.20 will from the beginning take mobility support functions into account and will thus likely be even more optimised with respect to mobility support than

IEEE 802.16e. Both 802.16e and 802.20 will be the likely competitors for WINNER Metropolitan and Wide Area deployments.

5. FLASH-OFDM®

5.1 Introduction/Background

Flarion, the Bedminster (New Jersey) based company is the inventor of a technology named FLASH-OFDM. FLASH stands for “Fast Low-latency Access with Seamless Handoff”. The FLASH-OFDM technology is designed for pure packet-switched transmission and smooth integration into IP-based network infrastructures. It aims at the delivery of Internet services in the mobile environment. Flarion is backed by a diverse group of investors including [Fla1]:

Bessemer Venture Partners

- Charles River Ventures
- Cisco Systems
- Equitek Capital
- New Venture Partners LLC
- Nassau Capital, LLC
- Pequot Ventures
- SK Telecom Co., Ltd
- T-Mobile Venture Fund

The development of FLASH-OFDM started in 1997 at the Bell Labs. In 2000 Flarion was incorporated with financial backing from Lucent Bell Labs and venture capitalists. In 2001 first technology trials were commenced. Since 2002 a product line is available and steadily commencing, consisting of:

- RadioRouter® Basestation
- Wireless Network Cards
- Chipsets
- 802.11g FLASH-OFDM Mobile Broadband Router

In January 2006 Flarion has been acquired by Qualcomm.

5.2 Technology

5.2.1 Overview

Flarion’s FLASH-OFDM air interface is designed to transparently support all existing IP-based applications in a mobile, wide-area network deployment. The technology is designed for use in licensed, bandwidth-constrained spectrum operating in a frequency division duplex (FDD) mode. According to Flarion, the FLASH-OFDM technology possesses the necessary attributes for mobile deployment, including power and spectrum-efficient operation with support for full mobility and quality of service, while providing broadband data speeds with only a single antenna at the wireless terminal. It has been designed from the outset to integrate into an IP-based network in a seamless fashion. The underlying assumption for this all-IP approach was that IP technology provides the most cost effective path to providing converged voice and data services.

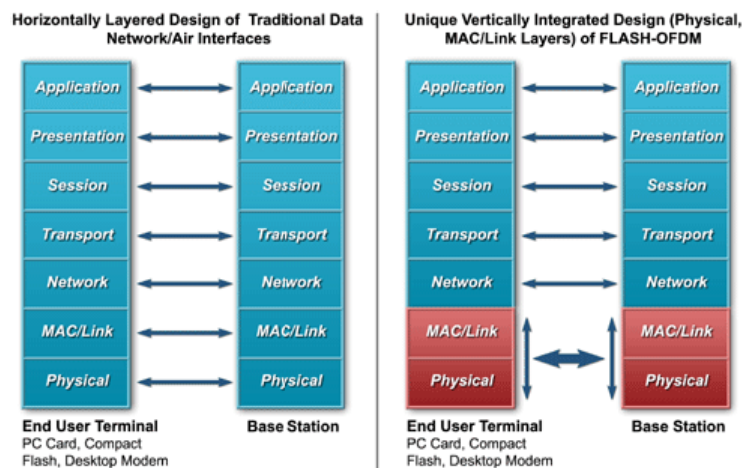

Figure 5-1: Scope of Flarion’s FLASH-OFDM technology with respect to the ISO/OSI reference model [Fla1]

Figure 5-1 depicts the scope of Flarion’s FLASH-OFDM technology with respect to the ISO/OSI reference model. From this figure it can be deduced, that the FLASH-OFDM technology spans MAC and PHY layer functionality. Similar to many IEEE standards, FLASH-OFDM is designed to integrate into the IP protocol suite from the “Network” layer upwards. In Figure 5-2 a typical mobile broadband network architecture is depicted. It is shown, how the Flarion RadioRouter® Base Station integrates into the IP-based transport network via edge routers.

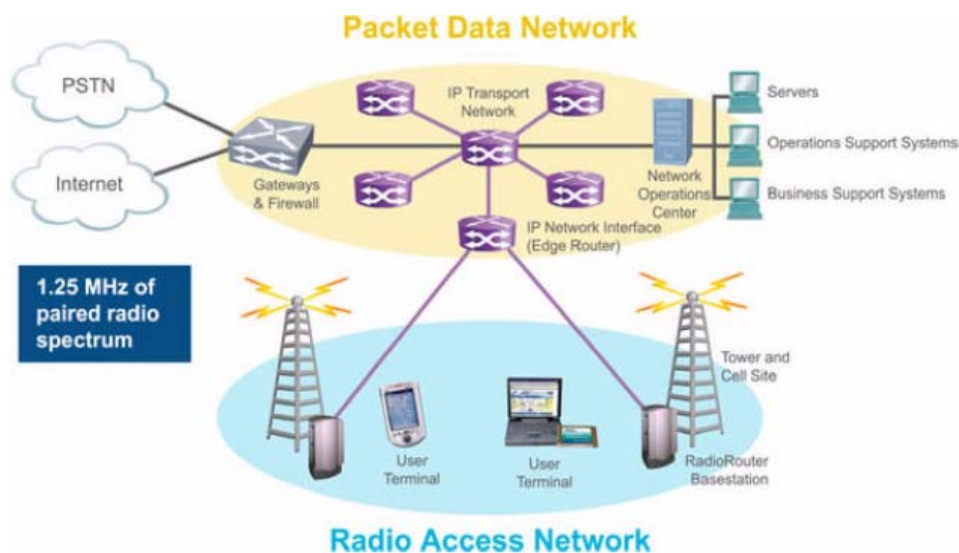

Figure 5-2: Overall architecture of a mobile broadband network using FLASH-OFDM technology [Fla7]

Flarion claims the following key characteristics for the FLASH-OFDM technology [Fla2]:

- Spectrally efficient, high capacity physical layer
- Packet-switched air interface
- Contention-free, QoS-aware MAC layer
- Support for interactive data application including voice
- Efficient operation using all existing Internet protocols (TCP/IP...)
- Full vehicular mobility
- Low cost

5.2.2 Physical Layer

5.2.2.1 Transmission Scheme

The transmission technique used by FLASH-OFDM is based on a fast tone hopping scheme. In this scheme users are allocated to OFDM subcarriers (tones) according to a pseudorandom predetermined hopping pattern. This hopping pattern ensures that users within the same cell are allocated orthogonal

resources and use a different subcarrier every symbol duration in downlink and every 7 symbol durations in uplink direction (cf. Figure 5-3 and Figure 5-4, respectively). Hence, users within the same cell do not interfere with each other. This is in contrast to CDMA systems, where the codes lose their orthogonality in presence of multi-path propagation. The hopping pattern covers all available subcarriers. By applying different hopping patterns to different base stations, interference between cells is averaged across all subcarriers leading to the advantages of frequency diversity and interference averaging as well as the possibility for a network deployment with a frequency reuse of one.

Figure 5-3 a) shows an example of the downlink hopping scheme used in FLASH-OFDM. Time-frequency resources bearing same colour belong to the same hopping sequence. In Figure 5-3 b) the construction of downlink logical channels of a series of channel segments each of which is constructed by some hopping sequence is shown.

Figure 5-4 a) shows the grouping of 7 OFDM symbols of which one is reserved for carrying a training or reference symbol for uplink channel estimation. The corresponding time period is called Dwell time. Figure 5-4 b) depicts an example of the construction of uplink logical channels from a number of channel segments.

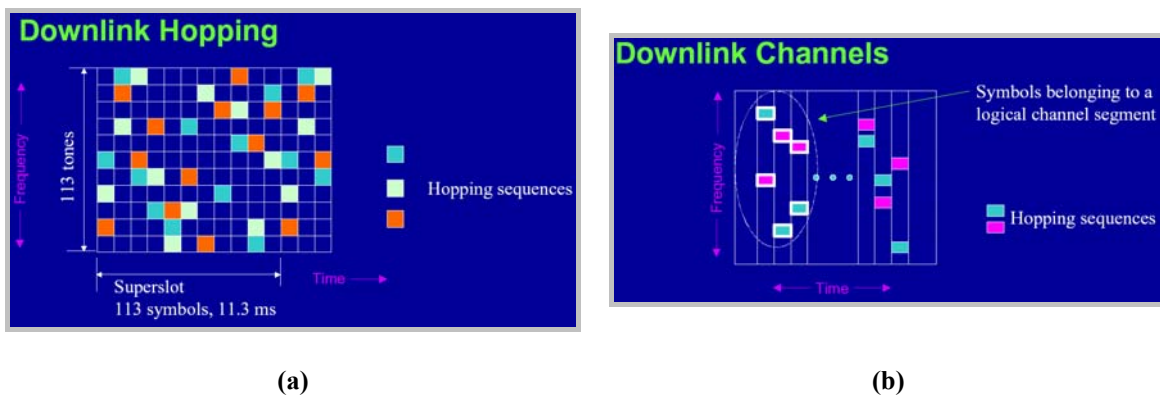

Figure 5-3: a) Downlink hopping scheme: symbol-by-symbol hopping, hopping sequence periodic with a superslot, hopping sequence different for adjacent cells; b) Construction of downlink logical channels [Fla9]

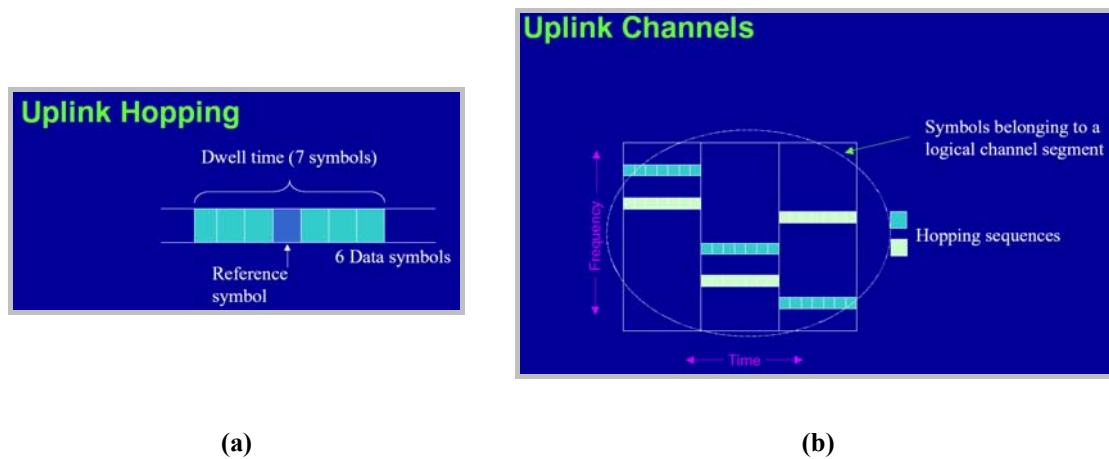

Figure 5-4: a) Uplink hopping scheme: tone hop once every 7 OFDM symbols, one reference symbol per 7 symbols (Dwell time), hopping sequence different for adjacent cells; b) Construction of uplink logical channels [Fla9]

5.2.2.2 Coding and Modulation

Another key feature of the physical layer, according to Flarion, is its Forward Error Correction (FEC) coding scheme based on Vector Low-Density Parity-Check (LDPC) codes. LDPC codes have random-like structure ensuring a powerful code while admitting simple decoding using iterative methods. The fundamental ideas behind iterative decoding first appeared in 1961 in the Ph.D. thesis of Robert Gallager, who introduced LDPC codes. LDPC codes are linear binary block codes. They are called low-density because they are defined by giving a parity-check matrix that is sparse, i.e., it has few non-zero entries. LDPC codes can be decoded with iterative soft-decision decoding algorithms called ‘message-passing’ algorithms. Flarion Technologies has developed a hardware architecture for encoding and decoding a specific class of LDPC codes known as Vector-LDPC codes, where the term “vector” refers to the parallel structure. The programmability of the Vector-LDPC architecture allows for multiple codes of different rates and block lengths to reside in a single hardware unit at once and switching between them incurs no overhead, which is important for supporting multiple users and fast link adaptation.

According to Flarion these codes outperform the well favoured turbo codes with 1/8th to 1/4th the complexity of the corresponding turbo code decoder [Fla3].

The flexibility of Vector-LDPC codes has been leveraged in the design of the FLASH-OFDM protocol. For the traffic channels, LDPC code words of relatively long block lengths (1344 to 5248 bits) are used in order to obtain coding gain. For channels used for control, access and signalling, code words of relatively short length (e.g., less than 300 bits) are used in order to decrease the latency of those messages. The modulation schemes supported by FLASH-OFDM include QPSK, 16QAM, 64QAM and 256QAM. The coding rates range from 1/6 to 5/6, and the system uses adaptive modulation to rapidly switch between codes.

Following parameters related to FEC coding are given in [Fla3]:

Traffic Channel	Code Type	Code rate	Length	Modulation
DL Traffic Channel	LDPC	1/6 to 5/6	1344-5248	QPSK- 256QAM
UL Traffic Channel	LDPC	1/6 to 5/6	1344	QPSK

Table 5-1: Code rates, codeword lengths and modulation schemes used in FLASH-OFDM

5.2.3 MAC and Link Layers

Because of the possibility to assign resources in a very high granularity in FLASH-OFDM Flarion claims that its MAC layer design is very efficient with respect to control signalling.

The FLASH-OFDM MAC Layer leverages the ability of OFDM to support many low bit rate dedicated control channels, enabling a large set of active users and traffic streams. FLASH-OFDM IP awareness provides the ability to distinguish between the priorities of each user's traffic and application services (packets flows are classified with fine granularity). Contention-free access in FLASH-OFDM also reduces overall latency, making the experience similar to wired broadband systems.

Another important aspects of the FLASH-OFDM MAC Layer according to Flarion is its ability to rapidly schedule active users between "On" state (users are downloading a web page) and "Hold" state (users are reading that web page). Sharing the transmission medium in real time between only those users who require it results in efficient use of bandwidth, low overall latency and enhanced QoS for a large number of mobile users.

The Link Layer runs over and utilizes the physical Layer to carry data from a transmitter to a receiver, and is responsible for network reliability. FLASH-OFDM provides high reliability through a Link Layer that features a fast Automatic Repeat Request (ARQ), which is used to check transmitted data for errors. If one is found, the message is retransmitted very quickly. Therefore, with loop times at less than 10 milliseconds, FLASH-OFDM ARQ latency is far lower than 3G cellular standards [Fla1]. This enables low latency retransmission of frames received in error. This combination of high reliability and low latency is critical for support of interactive applications, such as Voice over Internet Protocol (VoIP), instant voice and data messaging, online gaming and a host of other enterprise-specific applications. It also equates to overall performance.

5.2.4 Network Layer

FLASH-OFDM was designed to be seamlessly deployable within a pure IP-based network architecture and complies with the IETF architecture [Fla1], [Fla7]. As such, the technology utilizes IP mobility management, IP security and IP QoS, while removing the need for specialized radio access networks and complex/costly protocols.

Flarion's core product - the RadioRouter[®] base station - is a combination of a wireless base station and an IP access router, but provides fully mobile, wide area network coverage. All network access functionality resides in the RadioRouter base station, which wirelessly extends the edge of the IP network. The autonomy of the RadioRouter base stations is according to Flarion another key attributes of the FLASH-OFDM network layer. In adjacent cells, RadioRouter base stations do not need to be aware of each other, and timing or frequency synchronization is not required between them [Fla1].

5.2.5 FLASH-OFDM System Parameters and Characteristics

Table 5-2 summarizes the key parameters and characteristics of the FLASH-OFDM system. Some of the parameters are obtained from official White Papers which can be found at the Flarion Website [Fla1], whereas others (particularly the OFDM related parameters) stem from a contribution of Flarion within IEEE 802.20 standardisation [Fla9]. It is assumed, that the parameters given in [Fla9] comply with those used in the commercially available FLASH-OFDM products.

PHY	
Channel Bandwidth ⁴	1.25 MHz
Carrier Frequency ⁵	Up to 3.5 GHz
Spectrum Demand per Operator ⁶	2 x 1.25 MHz (minimum) 2 x 5 MHz (recommended)
Duplex Method ⁷	FDD
Multiple Access Method ⁸	OFDM-FDMA Frequency hopping across the tones, users within a cell are assigned one or a group of tones (subcarriers) in pseudo-random fashion
FFT size ⁹	128 (~88.8 μs)

⁴ [Fla6] p. 3, [Fla9] p. 9

⁵ [Fla9] p. 9

⁶ [Fla6] p. 8

⁷ [Fla6] p. 3

⁸ [Fla2]

⁹ [Fla9] p. 9

Cyclic Prefix ¹⁰	16 (~11.1 μ s)
Tone spacing ¹¹	11.25 kHz
Symbol rate ¹²	10 kHz
Tones used ¹³	113
Peak Sector Data Rates ¹⁴	DL: 3.2 Mbps, UL: 900 kbps (1 x 1.25MHz deployment)
Sustainable Sector Data Rates ¹⁵	DL: 1.25 Mbps , UL: 500 kbps (1 x 1.25MHz deployment)
FEC ¹⁶	Vector-LDPC codes DL: block length from 1344 to 5248 UL: block length 1344
Modulation ¹⁷	DL: QPSK, 16QAM, 64QAM, 256QAM UL: QPSK
Code rates ¹⁸	1/6 to 5/6
Equalisation ¹⁹	Only in UL, Turbo equalisation Uses a set of 7 QPSK symbols on 7 contiguous OFDM symbols where the 1 symbol is a reference/pilot symbol
Inter Cell Interference ²⁰	Different hopping patterns are used in adjacent cells to average inter-cell interference
LLC	
ARQ latency ²¹	Loop time of 5ms (this means, in a 35ms latency provided, the link can transmit the same data 6 times)
Average Latency ²²	50 ms
General	
Mobility ²³	250 km/h (maximum)

Table 5-2: FLASH-OFDM system parameters and characteristics

5.2.6 Summary

In summary Flarion claims the following advantages that FLASH-OFDM has over other radio access systems [Fla5] (mainly IEEE 802 standards based systems):

High-speed downlink and uplink based on OFDM: OFDM is a modulation and multiple access technique that divides the spectrum into a number of equally spaced tones, and carries a portion of a user's information on a tone. Each tone can be thought of as a frequency, much in the same way that each key on a piano represents a unique frequency. The OFDM tones have the very special property of being orthogonal, which means that the individual tones do not interfere with each other. In addition, the FLASH-OFDM system has no interference between users on the same cell. Therefore, FLASH-OFDM has at least a three times greater capacity than what is achievable with a CDMA-based system.

Fast ARQ and retransmission: The granularity of resource allocation offered by OFDM is of key value. OFDM makes it possible to transmit a single bit with essentially no overhead. Given this fact, a mobile terminal can power up, transmit a single bit, and power down. FLASH-OFDM enables a 5 ms ARQ loop

¹⁰ [Fla9] p. 9

¹¹ [Fla9] p. 9

¹² [Fla9] p. 9

¹³ [Fla9] p. 9

¹⁴ [Fla6] p. 7

¹⁵ [Fla6] p. 7

¹⁶ [Fla3] p. 8

¹⁷ [Fla3] p. 7

¹⁸ [Fla3] p. 8

¹⁹ [Fla3] p. 9

²⁰ [Fla9] p. 12, p. 15

²¹ [Fla5] p. 6

²² [Fla8] p. 11

²³ [Fla8] p. 11

time, which means that in a 35 ms window, the air link can transmit the same frame of data 5 times (including the initial transmission), ensuring reliable packet delivery – even for highly interactive applications.

A non-contention-based uplink: This means that a large number of users are able to access the system through the use of low bit rate, dedicated control channels. By avoiding the need for the contention-based access schemes used in 2G and 3G, FLASH-OFDM is able to further reduce latency, and enable the system to support differentiated services based on quality of service protocols such as Diff Serv.

The first end-to-end IP system: In being able to transport native IP packets without the need for costly and complex ‘IP assistance,’ FLASH-OFDM enables the operator to unwire the Internet “as is”, while being in full control of every packet that goes over the air link.

Handoff without a single packet loss: FLASH-OFDM’s proprietary make-before-break handoff technology eliminates network layer handoff latency for the majority of handoffs. For the minority of handoffs that occur in a break-before-make fashion, FLASH-OFDM’s proprietary zero-loss buffering scheme reduces or eliminates the incremental effects of handoff latency. Thus handoff latency is acceptable, even for critical applications such as VoIP and interactive gaming. These advantages allow FLASH-OFDM to provide a fraction of the delay in maintaining the data link than currently available and proposed 3G systems. In fact, the delay is so insignificant, the TCP/IP protocol thinks it is transmitting over a wired medium and keeps transmitting at a high broadband rate. Therefore, FLASH-OFDM, enabling both high data rates and low latency, is the only mobile broadband data system that will seamlessly and affordably extend today’s wired broadband user experience to a wireless environment. Without that seamless extension, the mass market will be slow to adopt wireless data.

With respect to benchmark WINNER against FLASH-OFDM, it can be said that FLASH-OFDM does not target very high data rates and spectrum efficiencies and thus is seen to be neither a direct competitor for WINNER Metropolitan nor Wide Area deployments, since WINNER aims for considerably higher data rates and spectrum efficiencies [W2D6.11.1]. However, FLASH-OFDM addresses the topic of very low ARQ loop time of 5 ms to tackle latency requirements of IP-based protocols such as TCP/IP. This topic will be also very important for the WINNER system design and must be carefully addressed.

5.3 Standardisation and Commercial Availability

5.3.1 Standardisation

5.3.1.1 Network Standards

With regard to networking standards, the core network that Flarion's RadioRouter base station interfaces with is already 100% IP standards-based. According to [Fla1] Flarion is committed to continue its ongoing involvement in data networking standards bodies IETF and IEEE, and to maintain compliance as these standards evolve. Flarion staff members include IETF working group chairs, editors of critical IP mobility standards, and key contributors to IPv6, Differentiated Services, Mobile Routing, and IP multicast standards. Flarion expresses furthermore commitment to promote these accepted IP architectures into the relevant wireless and telecommunications standards bodies in connection with its air interface work.

5.3.1.2 Air Interface Standards

Flarion began its standardisation effort in March 2002, by initiating a proposal in the IEEE 802 committee to work on an air interface for Mobile Broadband Wireless Access (MBWA). In July 2002 the IEEE 802 Executive Committee established an 802 Executive Committee Study Group to develop a project proposal. Flarion’s intention was to propose FLASH-OFDM as a candidate for IEEE 802.20. Flarion however did not submit its proposal in time. This is presumably because of the acquisition of Flarion by Qualcomm. Qualcomm is now pushing FLASH-OFDM as a candidate for 3GPP2.

5.3.2 Commercial Availability

Flarion provides a product portfolio consisting of RadioRouter[®], Basestation, Wireless Network Cards and Chipsets [Fla1].

6. Conclusion

This document lists existing systems that will serve for reference to the WINNER system when the performance of WINNER will be assessed. These systems correspond to different deployment scenarios in which the WINNER performance is assessed (Local Area, Metropolitan Area and Wide Area).

In Table 6-1 below peak and achievable spectral efficiencies per sector for these various systems are listed. As all of these systems are not yet deployed because of ongoing standardisation or implementation activities, only rough figures or ranges of achievable efficiencies can be provided. However, the highest values listed below can be considered as a minimum target WINNER should achieve for the respective deployment case.

Table 6-1: Spectrum efficiencies of the WINNER system and potential competing systems

System	Peak spectral efficiency per sector (DL / UL) b/s/Hz/sector	Achievable spectral efficiency per sector (DL/UL) b/s/Hz/sector	Deployment case with respect to WINNER CGs ²⁴
3GPP LTE	7.2 / 2.4	up to 2.6 / up to 0.9	WA (MA)
3GPP2 1xEV-DO Revision B²⁵	3.67 / 1.35	-	WA (MA)
IEEE802.11n	5.0	2.5 (target)	LA
IEEE802.16e	3.16 / 2.35	1.09-1.87 / 0.55-0.83	MA (WA)
IEEE802.20	3.6 / 1.8	1.5-2.0 / 0.75-1.0 (target)	WA (MA)
FLASH-OFDM	2.56/0.72	1.0/0.4	WA (MA)

In Table 6-2, forecasts on spectral efficiencies from ITU are provided. These values correspond to the theoretical limits achievable per-band and per-cell for IMT-advanced systems in the unicast cases. Values are provided for 2010, 2015 and 2020 horizons. We choose the macro-cell, micro-cell/pico-cell and hot-spot cases as defined in the ITU-R Report [IMTRAD] to compare with Wide Area, Metropolitan Area and Local Area WINNER deployments, respectively. In addition to these forecasted values, WINNER peak area spectral efficiencies per site targets are recalled. In WINNER a site is defined as the physical co-location of hardware serving a set of antennas. Since no assumptions should be made on the deployment scenarios spectral efficiency per site is preferred over efficiency per cell or sector.

Table 6-2: ITU spectral efficiencies forecasts and WINNER Targets

	Peak area spectral efficiency ²⁶ for WINNER targets [WIND7.1] b/s/Hz/site	WINNER target average spectral efficiency requirement [W2D6.11.1] b/s/Hz/sector	Average area spectral efficiency for IMT-advanced [IMTRAD] b/s/Hz/sector
Wide Area	10	2-3	2-4
Metropolitan Area	10 (15*) *Where some degree of isolation (e.g. street canyons) is possible	2-5	2-6
Local Area	25	10	5-10

²⁴ Deployment cases mentioned first are the main candidate deployments for the respective standard; deployments in brackets indicate possible alternative target deployments

²⁵ Revision C results were not available

²⁶ These peak spectral efficiency target requirements from WINNER Phase I have been replaced by average spectrum efficiency targets which have been defined by applying a well defined satisfied user criterion [W2D6.11.1].

References

- [23.101] TS 23.101, "General UMTS Architecture", 3GPP TSG Services and System Aspects
- [25.346] TS 25.346, "Introduction of the Multimedia Broadcast Multicast Service (MBMS) in the Radio Access Network (RAN), Stage 2 (Release 6)", 3GPP TSG RAN
- [25.401] TS 25.401, "UTRAN overall description", 3GPP TSG RAN
- [25.808] TR 25.808, "FDD enhanced uplink: Physical layer aspects," 3GPP TSG RAN
- [25.814] TR 25.814, "Physical Layer Aspects for Evolved UTRA (Release 7)", 3GPP TSG RAN, V1.0.3, May 2006
- [25.858] TR 25.858, "Physical Layer Aspects of UTRA High Speed Downlink Packet Access," 3GPP TSG RAN
- [25.896] TR 25.896, "Feasibility Study fore enhanced uplink for UTRA FDD" 3GPP TSG RAN
- [25.912] TR 25.912, "Feasibility Study for Evolved UTRA and UTRAN" 3GPP TSG RAN
- [25.913] TR 25.913, "Requirements for Evolved UTRA (E-UTRA) and Evolved UTRAN (E-UTRAN), (Release 7)", TSG RAN, v7.2.0, December 2005
- [25.950] TR 25.950, "UTRA High Speed Downlink Packet Access", 3GPP TSG RAN
- [25.992] TR 25.992, "Multimedia Broadcast Multicast Service (MBMS); UTRAN/GERAN Requirements", 3GPP TSG RAN
- [3GA04] 3G Americas, "The Evolution of UMTS/HSDPA – 3GPP _Release 5 and Beyond," June 2004, http://www.3gamericas.org/pdfs/umtsrel5_beyond_update-nov2004.pdf
- [3GA05] 3G Americas, "The Evolution of UMTS/HSDPA – 3GPP _Release 6 and Beyond," July 2005, http://www.3gamericas.org/pdfs/umtsrel6beyond_july2005.pdf
- [802.11] IEEE P802.11, Wireless LAN Medium Access Control (MAC) and Physical Layer (PHY) Specifications, 1999 Edition (2003)
- [802.11e] P802.11e/D13.0, Amendment: Medium Access Control (MAC) Quality of Service Enhancements, January 2005
- [802.11n] IEEE P802.11n/D1.0, Draft Amendment: Enhancements to Higher Throughput, March 2006
- [802.11s] IEEE P802.11s/D0.01, Draft Amendment: ESS Mesh Networking, March 2006
- [802.16e] IEEE P802.16e/D12, "Air Interface for Fixed and Mobile Broadband Wireless Access Systems", February, 2005
- [802.20] IEEE P802.20-PD-06, System requirements for IEEE 802.20 Mobile Broadband Wireless Access Systems – Version 14
- [DMR02] M. Döttling, J. Michel, and B. Raaf, "Hybrid ARQ and Adaptive Modulation and Coding Schemes For High Speed Downlink Packet Access," Proc. PIMRC 2002, Lisbon, Portugal, pp. 1073-1077, September 2002
- [Fac06] S. Faccin, C. Wijting, J. Knecht, A. Damle, "Mesh WLAN Networks: Concept and System Design", IEEE Communications Magazine, April 2006
- [Fla1] Flarion Website, <http://www.flarion.com>
- [Fla2] "OFDM for Mobile Data Communications", Whitepaper, Flarion Technologies, Inc., March 2003
- [Fla3] "Vector-LDPC™ Codes for Mobile Broadband Communications", Whitepaper, Flarion Technologies, Inc., November 2003
- [Fla4] "4 Ps for Carrier Employment of Mobile Broadband Systems Pipe, Protocol, Policies, and Profitability", Whitepaper, Flarion Technologies, Inc., January 2004
- [Fla5] "Low Latency The Forgotten Piece of the Mobile Broadband Puzzle", Whitepaper, Flarion Technologies, Inc., February 2003

- [Fla6] "Gigabyte Performance in a Mobile Broadband Network - Voice and Data Services over a Converged IP Network", Whitepaper, Flarion Technologies, Inc., February 2005
- [Fla7] "The Benefits of a Packet-Switched, All-IP Mobile Broadband Network", Whitepaper, Flarion Technologies, Inc., February 2004
- [Fla8] "FLASH-OFDM® for 450MHz Advanced Mobile Broadband Solution for 450MHz Operators", Whitepaper, Flarion Technologies, Inc., November 2004
- [Fla9] IEEE C802.20-03/16, "Initial Contribution on a System Meeting MBWA Characteristics", IEEE 802.20 Working Group on Mobile Broadband Wireless Access, March 6, 2003
- [IEC05] International Engineering consortium, "UMTS Network and Service Assurance," http://www.iec.org/online/tutorials/agilent_umts_network/topic03.html
- [HT04] H. Holma, A. Toskala, "W-CDMA for UMTS," John Wiley & Sons, 3rd edition, 2004
- [Jav05] A. Javed, "Disruptive Possibilities for Future Wireless Networks"
- [PEM04] S. Parkvall, et al., "W-CDMA evolved—High-speed packet-data services," Ericsson Review, No. 2, 2003
- [R1LteDL] R1-061630, "DL Summary of LTE System Performance Evaluation Results", Motorola, 3GPP RAN WG1 Meeting #45, Shanghai, China, May 8th – 12th 2006
- [R1LteUL] R1-061609, "Uplink Summary of LTE System Performance Evaluation Results", Motorola, 3GPP RAN WG1 Meeting #45, Shanghai, China, May 8th – 12th 2006
- [TS04] TeliaSonera, "Mobile Broadcast/Multicast Service (MBMS) – White Paper," August 2004, www.medialab.sonera.fi/workspace/MBMSWhitePaper.pdf
- [WCE02] Y.-P. E. Wang, J.F. Cheng, and E. Englung, "The Benefits of Advanced Receivers for High Speed Data Communications in W-CDMA," Proc. IEEE VTC 2002 Fall, September 2002,
- [UF05] UMTS forum, "HSPA: High Speed Wireless Broadband – From HSDPA to HSUPA and Beyond", www.umtsforum.org/servlet/dycon/ztumts/umts/Live/en/umts/MultiMedia_PDFs_Papers_White-Paper-HSPA.pdf
- [WiMAX] WiMAX Forum, Mobile WiMAX -- Part I: A Technical Overview and Performance Evaluation
- [WiMedia] The ECMA international standard, "High Rate Ultra Wideband PHY and MAC Standard", 1st Edition, Sept.2005
- [IMTRAD] ITU, SWG Radio Aspects, "Preliminary Draft New Report On Radio Aspects for the Terrestrial Component of IMT-2000 and Systems beyond IMT-2000", WP8F Meeting, Helsinki, October 2005
- [MCC03] 3GPP TSG RAN, "Overview of 3GPP Release 5," Tdoc RP 030375, RAN#20, Finland, June 2003
- [BB05] IST-2003-507607 B-BONE, "Final Results with Combined Enhancements of the Air Interface," December 2005
- [WIND7.1] IST-2003-507581 WINNER deliverable, "D7.1, System Requirements", June 2004
- [W2D6.11.1] IST-4-027756 WINNER II deliverable, "D6.11.1, Revised WINNER II, System Requirements", June 2006